

 **TAITRONICS**
Taipei International Electronics Show

 **AIoT Taiwan**
Taiwan International AIoT Show

EXHIBITOR MANUAL

OCT. 16-18, 2019

Taipei Nangang Exhibition Center, Hall 1 (TaiNEX 1)



Organizers:  TAITRA  TEEMA



www.taitronics.tw



www.aiottaiwan.com



Table of Contents

Checklist	1
1. Venue	4
2. Booth Setup/Dismantling and Exhibits Move-in & Move-out Hours	4
3. During Show Days	5
4. Security and Insurance.....	6
5. Booth Setup & Facilities	6
6. Electricity and Water/Drainage Requirements	7
7. Exhibitor Badges	7
8. Showground Facilities & Services	7
9. Promote Your Company	8
10. Support & Guidance of Online Fair Services	8
11. International Visitor’s Online Registration	10
12. Local Visitor’s Admission	10
13. Terms & Regulations	10
14. Telephone Rentals and Internet	13
15. Free Wi-Fi Service.....	13
16. Construction Guidelines for Second-story Booths	14
17. Construction Guidelines for Booths Exceeding 4 Meters	16
18. Wall Television/Sound System& Stage Equipment Setup.....	18
19. Regulations Regarding Use of the Promotional Balloons	19
20. Regulations on Work at TAITRA Venues.....	20
21. Customs Regulations for Foreign Exhibits	29
22. Personal Information Protection	32
23. Tariff for Heavy Duty Electric Power	33
24. Estimated Power Consumption for Electrical Appliances.....	34
25. Electricity & Water / Drainage Requirements	35
26. Booth Construction Assurance	36
27. Safety and Health Terms of Agreement.....	37
Att. Official Constructors Manual.....	41
- UNIPLAN Taiwan Corp.....	43
- O’YA Marketing Solution & Interior Design.....	63



Checklist

The following checklist is designed to guide and help you plan your work schedule for participating TAITRONICS and AIoT Taiwan 2019. If the following services are required, please return the completed forms to the designated person by the deadline. Services will not be guaranteed if the related forms are returned after the deadline.

Booth set up/move-in : Oct. 14-15
 Show Dates : Oct. 16-18
 Booth move-out : Oct. 18-19

Deadline (2019)	Services / Items	Contacts		Remarks
September 6	Forwarders (Shipping Arrangement) • Importation of Exhibits on a Bonded Basis • Commercial Invoice & Packing List	Eurotran Expo Service	Tel: 886-2-2785-6000 Fax: 886-2-2785-6701 Email: info@eurotran.com	Page 31
		Triumph Express Service	Tel: 886-2-2781-1133 Fax: 886-2-7645 Email: triumph@ms8.hinet.net	
	Promotional Balloon Application and Liability Form	Exhibition Dept., TAITRA	Ms. Jill Chiu Tel: 886-2-2725-5200 ext. 2684 E-mail: taitronics@taitra.org.tw Add: No. 5, Sec. 5, Xinyi Rd., Taipei 110, Taiwan	Page 19
	Wall Television / Sound System / Stage Equipment Setup			Page 18
Meeting Room Package	Exhibition Dept., TAITRA	Mr. Cavan Pai Tel: 886-2-2725-5200 ext. 2874 E-mail: cavan@taitra.org.tw Add: No. 5, Sec. 5, Xinyi Rd., Taipei 110, Taiwan	Page 38	
September 11	Electricity & Water/Drainage Requirements (20% off by August 31) • Additional or heavy-duty power Supply • Technical Support	Taipei Nangang Center, Hall 1, TAITRA	Ms. Chan Tel: 886-2-2725-5200 ext. 5569 Email: power5563@taitra.org.tw	Page 34
September 13	Put Ads in Directory	China Economic News Service	Mr. You Tel: 886-2-8692-5588 ext.2032	Page 7
	Sponsor Facilities at the Venue	Exhibition Dept., TAITRA	Mr. Abby Chan Tel: 886-2-2725-5200 ext. 2608 E-mail: yiwei@taitra.org.tw	



Deadline (2019)	Services / Items	Contacts		Remarks
	Booth Setup & Facilities (Official Contractors)	UNIPLAN Taiwan Corp.	Tel: 886-2-2758-5450 Email: twtc@uniplan.com.tw	Page 40
		O'YA Marketing Solution & Interior Design	Tel: 886-2- 2655-2777 Email: daven@o-ya-design.com	
September 13	Application for Pillar Decoration	Exhibition Dept., TAITRA	Ms. Jill Chiu Tel: 886-2-2725-5200 ext.2684 E-mail: taitronics@taitra.org.tw	
	Telephone Rental/Internet	Taipei Nangang Center, Hall 1, TAITRA	Chunghwa Telecom Tel: 886-2-2720-0149	Page 12
	Application for Construction of Booths Height Exceeding 4 Meters	Exhibition Dept., TAITRA	Ms. Jill Chiu Tel: 886-2-2725-5200 ext.2684 E-mail: taitronics@taitra.org.tw Add: No. 5, Sec. 5, Xinyi Rd., Taipei 110, Taiwan	Page 15
September 20	Required to submit "Booth Construction Assurance" & "Safety and Health Terms of Agreement"	Taipei Nangang Center, Hall 1, TAITRA	Mr. Brian Wen Tel: 886-2-2725-5200 ext. 5515 E-mail: brianwen@taitra.org.tw	Page 35
September 26	Submission of Booth Electricity Layout	Taipei Nangang Center, Hall 1, TAITRA	Ms. Chan Tel: 886-2-2725-5200 ext. 5569 Email: power5563@taitra.org.tw	Page 7
September 27	Application for Additional Exhibitor's Badges	Exhibition Dept., TAITRA Exhibitors Registration Counter	Ms. Jill Chiu Tel: 886-2-2725-5200 ext. 2684 E-mail: taitronics@taitra.org.tw Add: No. 5, Sec. 5, Xinyi Rd., Taipei 110, Taiwan	Page 7
	Application for Construction of Second-Story Booths			Page 14
	Application for Electric Forklifts			Page 26
	Application for Automobile & Motorcycle Display			



Deadline (2019)	Services / Items	Contacts		Remarks
October 14-15	Exhibitor Badges Pick-up (4 badges per booth)	Exhibition Dept., TAITRA Exhibitors Registration Counter	Ms. Jill Chiu Tel: 886-2-2725-5200 ext. 2684 E-mail: taitronics@taitra.org.tw Add: No. 5, Sec. 5, Xinyi Rd., Taipei 110, Taiwan Pick up at the Exhibitors Registration Counter at Taipei Nangang Exhibition Center, Hall 1 during move-in hours by showing business card and a filled "Booth Construction Assurance" & "Safety and Health Terms of Agreement" Form.	Page 7

* Application Forms for *promotional activities, pillar decoration, liquid nitrogen using, electric forklifts* and *heavy vehicles* are in Chinese edition only, please have the constructor to apply.



1. Venue

Taipei Nangang Exhibition Center, Hall 1

No. 1, Jingmao 2nd Rd., Nangang District, Taipei, Taiwan

2. Booth Setup/Dismantling and Exhibits Move-in & Move-out Hours

Date	Time	Items
October 14	07 : 00 - 17 : 00	Booth Set up/move-in
October 15	07 : 00 -18 : 00	Booth Set up/move-in
October 16	09 : 00 - 18 : 00	Show Dates
October 17	09 : 30 - 18 : 00	*Exhibitor's Entrance Time:
October 18	09 : 30 - 17 : 00	October 16-17 10:00-18:00 October 18 10:00-17:00
October 18	17:00 - 19:00	Exhibits Move-out * Vehicles are not permitted to enter.
October 19	07 : 00 - 16 : 00	Booth Dismantling

- (1) During move-in, **small passenger vehicles are denied entry to showground.** Showground entry is restricted to cargo trucks and authorized trucks.
 - Vehicles are allowed access to showground exclusively from Jingmao 1st Rd. cargo entrance.
 - **Vehicles are prohibited from parking on 3m lanes within the showground.** Vehicles are permitted to park on 6m lanes or outside the showground to unload their cargo to have cargo carted into showground.
- (2) The Maximum height clearance for trucks is 4 meters. For entry of trucks over 4 meters high (with or without goods) into the premises, requests must be submitted to the Management Section of TAITRA (including trucks over 4.25 meters in height), and after receiving permission, they can enter via the designated route at designated times.
 Height limit of Cargo Doors are as follows:
 Area I — 5m Area J — 4.5m Area K — 5m
 Lower entrance of access ramp 8m, upper entrance/exit of access ramp 6.7m
- (3) For safety precautions, an application must be submitted by September 21 in order to allow trucks with a total weight of 15 tons (based on what is labeled on the vehicle or the driver's license), or large cranes (15 tons and above) or tow trucks to enter.
- (4) **Only electric forklifts (2.5 tons and below) are allowed into the showground.** For forklift rental, please have the constructor to contact Shang-Sheng Forklift: Tel: 886-2-25024216 or Yi-Chang Forklift: Tel: 886-2-85210088.
- (5) **No excavators are allowed.**
- (6) One vehicle per exhibitor is allowed into the showground at a time. In order for a truck to enter the exhibition halls, a temporary deposit of NT\$1,000 must be paid at the entrance. The entire deposit will be returned upon move-out within one hour. NT\$200/hr will be deducted from the deposit for overstaying beyond the hour allotted.
- (7) Vehicles are not permitted to enter the showground after 5 p.m. during move-in days.



(8) Booth decoration and exhibit set up must be completed on time.

3. During Show Days

Dates	Taipei Nangang Exhibition Center, Hall 1	
	Oct. 16-17, 2019 (Wednesday to Thursday)	10 : 00 – 18 : 00
	Oct. 18, 2019 (Friday)	10 : 00 – 17 : 00
Admission	Oct. 16-17	Open to International visitors and local professionals.
	Oct. 18	Open to International visitors, local professionals, and the general public.
Policies	Online International Visitors Registration: www.taitronics.tw / www.aiottaiwan.com/ Minors under 18 years of age will not be admitted.	

- (1) **No exhibits can be moved in or out during show hours.** If an exhibit has to be carried in or out, it should be done before 10 a.m.
- (2) **Exhibitors should display their company name on their sign at their booth area.** Participants shall not assign, sublet, or apportion any part of the assigned space assigned to others or have representatives, equipment, or materials from other firms appear in the exhibition space. Any violation will affect exhibitors' participation in the next two years.
- (3) Exhibitors should keep their booths open and staffed at all times during show hours. The organizer reserves the right to restrict noise level to no more than **85dB** and to require suitable methods of operation and display of materials.
- (4) **Retail sales are strictly prohibited.**
 - (5) Should any rented space remain unoccupied on the opening day without just cause, the organizer reserves the right to rent the said space to another exhibitor or use the said space in any other manner deemed suitable.
- (5) Exhibitors should make sure to **get a license or have the authority of Public Performance and Display Rights for all music displayed during show dates.**
- (6) **Exhibitors are strictly prohibited from occupying the aisles or public areas, as well as handing out brochures outside their booth stand.** The organizer will confiscate all items in violation of the above without recourse for compensation. Violations will be recorded and participation in future show events will be affected.
- (7) The organizer is responsible for daily cleaning of public areas and passageways only. Exhibitors have to take care of the cleanliness of their own booths.
- (8) The organizer reserves the right to determine the acceptability and extent of product demonstrations.
- (9) **Smoking is strictly prohibited in the exhibition hall.**



4. Security and Insurance

- (1) While every reasonable precaution is taken in regard to ground security, **the organizer accepts no responsibility for any loss or damage** which may befall the person or property of the exhibitor regardless of cause.
- (2) Particular care should be taken on the final evening of the show when the risk of loss of goods is the greatest. Exhibitors should not leave their booths unattended especially during this period of time.
- (3) The exhibitor is responsible for securing insurance coverage against all risks associated with participating in the exhibition including fire, theft, flood and accident. Coverage should be for the duration of the exhibition (including move-in and move-out) and should include:
 - a. Exhibits and other items located in the booths
 - b. Public liability
 - c. Third party liability
 - d. Expenses incurred due to cancellation or postponement of the exhibition
- (4) Exhibitors are also advised to insure their exhibits for the time their goods are in storage. The organizer is not liable for any damage, loss, distress or harm caused to any person or to any person's property on the exhibition ground regardless of cause.

5. Booth Setup & Facilities

A standard booth measures 3 by 3 meters, including 500 watts (110V) electricity power supply. Booth facilities are available on a rental basis from the official contractors, **UNIPLAN Taiwan Corp.** and **O'YA Marketing Solution & Interior Design**. Please refer to TAITRONICS / AIoT Taiwan official website for details. Fireproof materials are needed to construct booths in Taipei Nangang Exhibition Center, Hall 1.

Booth Rentals

General booth (raw space) : US\$ 2,080

Booth with shell scheme: US\$ 2,280

- Raw space only (facilities and decoration not included)
- Booth with shell scheme (booths with basic setup & facilities included)

Remarks:

1. The booth can be ordered RAW SPACE ONLY, without partition, carpet, or any display facility or with shell scheme, basic booth setup & facilities.
2. Booth facilities are also available for rent from the official contractors. For samples of booth design, please see page 41.
3. Each booth will be provided with 110V/500W electricity free of charge. Additional power supply and drainage will be at exhibitor's expense.



6. Electricity and Water/Drainage Requirements

- (1) Each booth is supplied with 110V/500W of power free of charge during show hours. Please have your constructor to **submit the booth electricity layout by September 26**. Exhibitors requiring additional or heavy-duty power supply or water drainage should submit an application and see **page 7** for reference.
- (2) Electricity will be provided on the day before the show from 8 a.m. to 6 p.m.
- (3) Electricity will be provided during show hours.

Oct. 16, 2019	9 a.m. to 6:30 p.m.
Oct. 17, 2019	9:30 a.m. to 6:30 p.m.
Oct. 18, 2019	9:30 a.m. to 5:30 p.m.
- (4) To ensure electrical safety of exhibits, exhibitors should install Active Voltage Regulation/Regulator (AVR) or Uninterruptible Power Supply (UPS).

7. Exhibitor Badges

- (1) Exhibitor badges are available for pick up during move-in hours starting **Oct. 14**. All exhibitors should register at the Exhibitor's Registration Counter at the Taipei Nangang Exhibition Center, Hall 1 to collect exhibitor's badges by providing **business cards** which indicate exhibitor's company name or by presenting a letter of authorization from the exhibitor, together with a signed "**Booth Construction Assurance**" & "**Safety and Health Terms of Agreement**".
- (2) **Four** exhibitor's badges are allotted for each booth. These serve as entry passes to the exhibition halls and must be worn for entry into the showground. Each additional badge costs **NT\$300**. Exhibitors may apply online before **September 27, 2019**. After receiving of the application, we will notify you of the payment due by e-mailing you the Invoice.

8. Showground Facilities & Services

Showground Services	Taipei Nangang Exhibition Center, Hall 1	Tel: 886-2-2725-5200
Show Information Center	Lobby, Main Entrance, Ground Level	Ext. 5101, 5111
Press Room	Sky Dome (4 th Floor)	Ext. 5425
Luggage Storage Room	Room 145, Ground Level	Ext. 5132
Conference/Meeting Rooms	Sky Dome (4 th Floor) & 5 th Floor	4F: Ext. 5439, 5440/5441, 5445 5F: Ext. 5582, 5585, 5588
First Aid	Room 158, Ground Level	Ext. 5582, 5585, 5588
Breastfeeding Room	Room 115, Ground Level	
Forwarders	Eurotran Expo Service	886-2-2785-6000
Forwarders Express Courier	Triumph Express Service	886-2-2581-1133
	Information Counter, Area M Lobby, Ground Level	Ext.5402
Tourism Information	Lobby, Main Entrance, Ground Level	Ext.5102
Parking Area	Basement 1	Ext.5001
Café/Bakery/Fast Food/ Snack Bars/Drinks	Ground Level	Ext.5157,5150, 5152, 5153, 5156, 5151
Convenience Store	Ground Level	886-2-2651-9408



9. Promote Your Company

(1) TAITRONICS Official Website Online Promotion (*Free Promotion*)

The official website of TAITRONICS www.taitronics.tw is the best platform for exhibitors to announce the latest products. Right on the homepage, simply click on “Login”, select the function of “Product Catalogue” to upload products information. Exhibitors are also welcome to download and use the TAITRONICS key visual and banners available on the official website.

(2) Advertising in the Official Publications

TAITRONICS provides different types of publication including Show Daily, Show Map and Show Guide. For placing an advertisement, please contact:

Ms. Abby Chan, Tel: 886-2-2725-5200 ext. 2608, E-mail: yiwei@taitra.org.tw.

(3) Advertising in the Official Directory

Exhibitors interested in putting paid ads in the official directory may contact:

Mr. You, Tel: 886-2-8692-5588 ext. 2032

(4) Exhibitor’s Sponsorship at the show

To better expose yourself to trade visitors and media, you are welcome to sponsor selected items during the show.

Application Deadline: **September 13, 2019**

Please contact:

Ms. Abby Chan, Tel: 886-2-2725-5200 ext. 2608, E-mail: yiwei@taitra.org.tw.

(5) Wall Television / Sound System Setup (Deposit Required)

If exhibitors use video films or sound system to promote your products, you need to apply on an application in advance. For setting regulation, please see **page 18**.

Application Deadline: **September 6**.

(6) Promotional Balloon Application & Liability Form (Deposit Required)

No distribution of small helium balloons in the exhibition hall. Erecting a balloon above your booth will raise a beckon at the show. For construction guidelines, please see **page 19**.

Application Deadline: **September 6**.

10. Support & Guidance of Online Fair Services

The Online Fair Services system is designed to help you prepare for the show with ease.

Follow the steps below, and you will be well on your way to successful exhibiting.

STEP 1: Activate Your Account

After successfully applying for participation, you will receive an activation email from TAITRONICS and AIoT Taiwan 2019 with a link. Click the provided link and follow the instructions to create your account and password. If you did not receive the activation email, please write to terry.tsao@taitra.org.tw.

STEP 2: Log in to OFS



Open your browser and navigate to **www.taitronics.tw**. On the main page, click **Exhibitor** and find the **Exhibitor Login** icon then click it go to the **Exhibitor Login** page. Next, enter your account and password to log in, as the screenshot below shows.

<p>Step 2.1</p>	
<p>Step 2.2</p>	
<p>Step 2.3</p>	

STEP 3: Apply for the Services You Need

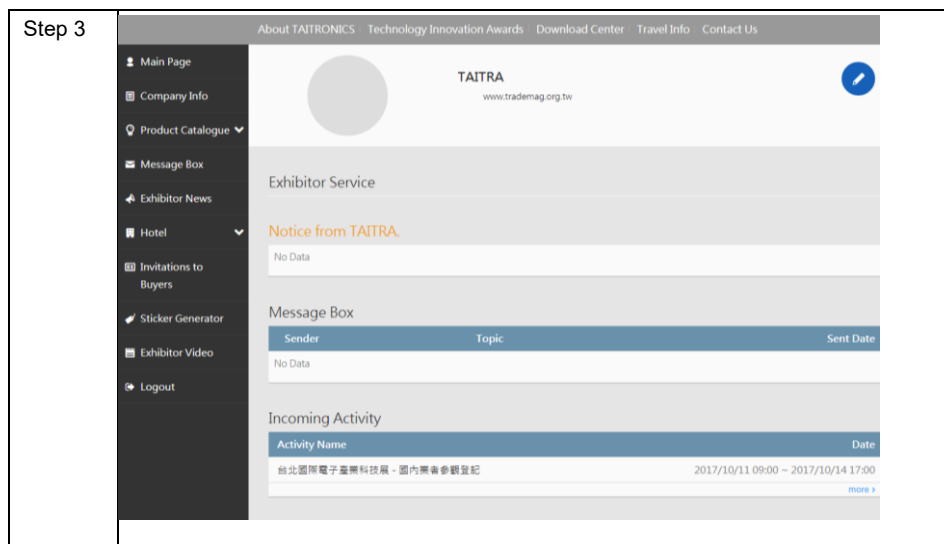

If you have questions or suggestions for this system, please contact crm44@taitra.org.tw.

11. International Visitor's Online Registration

International visitors are encouraged to pick up badges as early as possible at:

- (1) "Registered Visitor" counter, if international visitors have registered online at the official website : **www.taitronics.tw**.
- (2) "On-site Registration" counters, if international visitors have not registered online yet.
- (3) **Admission is free-of-charge for international visitors.**

12. Local Visitor's Admission

Local professionals can register and collect visitor badges on site. Please bring one business card. Visitors under age 18 are not admitted.

13. Terms & Regulations

TERMS AND REGULATIONS FOR PARTICIPATION

1. Participation Application

- (1) When registered online for TAITRONICS and AIoT Taiwan 2019, participants agree to follow all existing Regulations and further Regulations that might be made to modify them.
- (2) Once submitted by the applicant and confirmed by the Show management, the contract will be established and come into effect.
- (3) Violations of the Regulations can result, upon decision of the Show management, in the exclusion of the transgressors whose damage claim, if any, will be rejected.

2. Payment Scheduled

A deposit of US\$500 per booth has to be paid before the allocation meeting. An invoice for the remaining balance will be sent to the applicant after the booth allocation meeting. The remaining balance of booth rental should be made before the date stipulated by the Show management, TAITRA, otherwise your participation in the show will be cancelled. In the event



of cancellation, **any payment made will not be refunded under any circumstances.**

3. Adherence to Copyright Patent Laws

- (1) It is strictly forbidden to display logos or products that are licensed or have patents registered by other companies.
- (2) It is strictly forbidden to infringe an intellectual property rights or other rights of any third party.
- (3) Violations will result in immediate removal of the displays, and the exhibitor will not be permitted to participate in this same event for the next two years. Exhibitors bear the responsibility for all penalties without recourse or indemnity.

4. Space Assignment & Unoccupied Space

The Show management reserves the right, should any Exhibitors' space remain unoccupied on the opening day without reasonable cause, to assign the said space to another exhibitor, or use the said space in any other manner deemed suitable.

5. Sub-letting of Space

- (1) **The Exhibitor shall not assign, sub-let or apportion the whole or any part of the assigned space to firms other than his own.**
- (2) Violations will result in immediate removal of the displays, and the exhibitor and the other party will not be permitted to participate in this same event for the next three years. The exhibitors bear the responsibility for all penalties without recourse or indemnity.

6. Venue & Show Dates Change

The Show management reserves the right to change the venue and date of the Exhibition under certain circumstances. In the event of a change of venue and/or date, or cancellation of the Exhibition, the Exhibitors shall not be entitled to any claim for compensation in connection with the booking of participation.

7. Construction/Decoration of Stand and Removal of Exhibits from Hall

- (1) All exhibitors should comply with rules and regulation in the Exhibitor's Manual and complete their construction and/or decoration by the date and time stipulated by the Show management.
- (2) Exhibitors must remove all exhibits from the Exhibition Hall within the move-out period stipulated by the Show management. They will be held responsible for any loss or damage to Exhibition Hall due to delayed removal.

8. Insurance

- (1) In addition to insurance for exhibits in transit between the port of shipment and the fair site, exhibitors are advised to take out adequate insurance (fire, theft, water, accident, natural disasters and third party liability, etc.) for their exhibits during the exhibition (incl. build-up and dismantling period), and during storage in the Show management's warehouse.



- (2) Exhibitors are advised to hire their own security guards, for their valuable exhibits during the exhibition period (incl. build-up and dismantling period).

9. Exhibit Limitations

Exhibitors are not permitted to erect booth partitions of over 250 cm in height.

Advertising materials such as signs, posters and other advertising decorations can be extended to a height of 400 cm. Any signs or decoration higher than 250 cm in full view must be decorated.

10. Selling From The Stand

The sale of exhibited goods on the spot and the soliciting of customers outside stands are strictly forbidden and those doing so can be immediately expelled from the exhibition.

11. Breach of Contract and Withdrawal by Exhibitor

- (1) In case of the Exhibitor's refusing the use of whole or a part of the space allocated or in case of exhibitor default in payment by the stipulated date, show management has the right to terminate the contract forthwith and the part of rental already paid shall not be refunded.
- (2) In case of the Exhibitor withdrawing from participation, rental fees already paid by the Exhibitor shall not be refunded.

12. Security & Organizer's Liability

- (1) The Show management will provide personnel for maintaining order during the show period. Responsibility for guarding stands during the build-up, exhibition hours, and dismantling period, shall rest with the exhibitors concerned.
- (2) During the booth erection and dismantling period and during the show, booths must be staffed by personnel at all times.
- (3) The Show management shall not be held accountable or liable for, any damage, loss, harm or injury to any person or the property of the Exhibitors or of the exhibitor's officers, and/or employees, agents, and visitors which result from theft, fire, water, accident natural disasters or any other cause.
- (4) All Exhibitors are requested to turn off the power supply before leaving the exhibition booth. Unless otherwise agreed, the Show management will disconnect the main power supply at the stipulated times.

13. Operation

- (1) The Exhibitor shall keep his booth(s) staffed at all times during show hours.
- (2) The Show management reserves the right to restrict exhibits to a minimum noise level. Sound volume of any display should not exceed **85 dB**.
- (3) The Show management reserves the right to reject the exhibits or to stop the exhibition on the exhibitor's account, if he fails to lower the noise level or to resolve exhibition pollution such as dust, smog, unpleasant odors, the emission of gases, volatile organic chemicals or other contaminants.



14. Interruptions and/or Disruptions of Exhibition

Exhibitors shall not cause interruptions and/or disruptions of the exhibition, which result in protest or commotion at their booths, either inside or outside the show grounds, due to private disputes at any time during the exhibition or during move-in and move-out. If and when such an interruption and/or disruption influences the order of the exhibition or public image of the Show management, and the exhibitor involved or concerned is unable to deal effectively with private disputes and/or protests, the exhibitor understands and agrees that the Management can terminate the exhibition agreement. The exhibitor's booth(s) may be shut down immediately without refund. The exhibitor shall be required to indemnify the Management against any and all claims, liabilities, costs and expenses arising of such interruptions and/or disruptions thereof.

15. Supplementary Clauses

- (1) Whenever necessary, the show management shall have the right to issue supplementary regulations in addition to those indicated in the terms and regulations for participation to ensure the smooth management of the exhibition.
- (2) Any additional written regulation shall form part of the terms and regulations for participation and shall be binding on the exhibitor.
- (3) In the event of any occurrences not foreseen in this manual, the decision of the organizer shall be final.
- (4) When signing the prescribed application forms, participants agree to follow all the existing regulations and further regulations that might be made to modify them.
- (5) Once signed and submitted by the applicant and confirmed by the show management, the contract will be established and come into effect.
- (6) Violations of the regulations can result, by decision of the show management, in the exclusion of the transgressors whose damage claim, if any, will be rejected.

14. Telephone Rentals and Internet

Telephone connections to booths may be ordered **only by the exhibitor's representative /agent in Taiwan**. The representative/agent must apply 1 month in advance directly to:
Chunghwa Telecom / Tel: 886-2-2720-0149

15. Free Wi-Fi Service

The Wi-Fi system enables 10,000 end-user devices to access free internet service. It also does away with the need to set up private internet facilities like Wi-Fi access points and Wi-Fi hotspot sharing.

(1) Access locations:

First floor exhibition area of Taipei Nangang Exhibition Center, Hall 1, Sky Dome and all public hallways, B1 Dining Area, and meeting rooms on the first, third, fourth, fifth and sixth floors.

(2) Basic equipment required for using the Wi-Fi internet connection:

- Notebook computer, tablet computer or smart phone.
- Wi-Fi-certified wireless network cards compliant with 802.11a/b/g/n/ac.



- Cards operating at 2.4GHz (wireless card protocols: b/g/n) are more susceptible to channel interference, resulting in poor internet connection quality. Try to use equipment that supports the 5GHz (wireless card protocols: a/n/ac) for accessing the internet.

(3) Taipei Nangang Exhibition Center, Hall 1's Wi-Fi SSID are as follows:

- TWTC Free (For buyers and visitors, no password required)
- TWTC Vendor (Exhibitors can obtain password from event organizer)
- TWTC Press (Domestic & foreign journalists can obtain password from event organizer)

(4) Notes for using the Wi-Fi Service:

- This service is intended solely for the provision of basic E-mail sending/receiving and for webpage browsing by buyers, exhibitors and journalists.
- **There are many competing Wi-Fi devices within the 2.4 GHz band, such as Bluetooth devices, wireless speakers, wireless audio electronics, microwave ovens, plus the AP equipment set up by exhibitors that will affect the Center's Wi-Fi service quality; as a result, only the 5 GHz service will be provided on the first floor and Sky Dome, and all other areas will have both 2.4 GHz and 5 GHz services.**
- Wi-Fi access speeds will be affected by the network terminal equipment's performance, placement, distance, building (decoration) shielding, electromagnetic radio frequency interference (such as those mentioned in the second item above), the host website's bandwidth, and numerous other factors; if this causes direct or indirect damage or loss, the Center assumes no liability for damages.
- Use of software/hardware systems which interfere with or sabotage other online users or nodes, such as disseminating computer viruses, attempting to hack into unauthorized systems, is strictly prohibited.
- Taipei Nangang Exhibition Center, Hall 1 shall terminate the rights to use the service in the event of a personal device being infected with a virus or is making malicious attacks on other computers which may compromise internet connection quality.
- Users shall avoid violating copyright laws or engaging in illicit online activities. Any legal liability resulting from such violations shall be borne solely by the user(s).
- Users shall comply with Taipei Nangang Exhibition Center, Hall 1's related internet usage guidelines when using the Wi-Fi service. For violators, the exhibition hall shall terminate the perpetrator's access rights to the service.

(5) Taipei Nangang Exhibition Center reserves the right to change or terminate this service at any time without providing notice.

16. Construction Guidelines for Second-story Booths at Taipei Nangang Exhibition Center, Hall 1

- (1) In view of an increasing demand for exhibit space, these Guidelines have been established for the construction of second-story booths. To set up second-story booths, trade show participants must comply with these Guidelines to ensure the safety and overall tidiness of the exhibition site.
- (2) The second-floor of the booth is restricted to meetings with buyers only. It cannot be used as storage space, or as an exhibition or promotional area.
- (3) With booth units measuring 3m x 3m, trade show participants must rent at least four (4) units, totaling an area of 6m x 6m, in order to be eligible to apply for the construction of second-story



booths.

(4) To apply for the construction of second-story booths in any TAITRA Taipei trade show, participants must submit the following data along with the deposit of **NT\$10,000** to the organizer, TAITRA, by registered mail before **September 27**. Construction cannot begin without prior written approval from TAITRA. The deposit will not be returned for any violation.

- One copy of the **Application Form (please have your constructor to submit the application)**
- One copy of the booth layout plan
- One copy of the construction plan (including plan, elevation and side drawings with specific dimensions, a list of building material, and indications of the floor load with maximum number of people allowed on the second floor), the structure plan and structure calculation report, all of which must be approved and signed by a licensed architect, civil engineer, or structural engineer, and have a scale of no less than 50:1.
- A copy of the architect, civil engineer, or structural engineer's license, certificate, and letter certifying membership from the related professional association, as well as the safety confirmation report on second-story booths.

(5) Charge for the use of the second-story booths is based on the floor area (including staircases).

The rate for second floor space shall be set in accordance with the date of full payment, as listed :

Full Payment Date	Rate
On or before September 6	40% of ground floor unit rate
September 7-27	70% of ground floor unit rate

(6) After obtaining construction approval from TAITRA, the applicant must purchase accident and third-party liability insurance of no less than NT\$2,000,000 for each person and each accident. The insurance should cover the show period and include the events move-in to move-out days. A copy of the insurance policy should be sent to TAITRA ten days prior to the move-in day, before construction can begin.

(7) The architect, civil engineer or structural engineer who has approved the construction plan or the designated deputy, should inspect on site the construction and dismantling of booths. Upon completion of construction, the architect must issue a certificate of completion to ensure that the booths have been constructed in accordance with the plans, and that safety is guaranteed.

(8) The floor of the second-story booth should not exceed 2.5 meters in height from the ground, and the total height of the second-story booths should not exceed 4 meters.

(9) The second-story of the booths must be equipped with a safety railing, the height of which should be at least 90cm, and not exceed 150cm. The height of partitions should not exceed 150cm, and no ceilings should be built over the second-story.

(10) The total floor area (including staircases) of the second-story should not exceed 70% of the area of the ground booth, and should be limited to 100 square meters.

(11) The recessed distance between booth unit boundary lines, and the front and sides of the main body of the first and second-story booths (including corporate signs) should be maintained at 50cm, and the exterior of the walls should be decorated.

(12) If the usable floor area of the second-story does not exceed 50 square meters, there should be



at least one staircase; if the area exceeds 50 square meters, there should be at least two staircases. The distance between any point on the second floor and the staircase should not exceed 10 meters.

When there are two staircases, they should not be set on the same side. The width of the stairway should be no less than 75cm, and a warning sign specifying the maximum load and number of people allowed on the second-story should be displayed in the staircase. The participating company should take responsibility for monitoring the number of people on the second-story.

- (13) The load-bearing capacity of the second-story should be no less than 200 kg/m², and that of the staircase no less than 300 kg/m².
- (14) The construction of booths should not present any hazard to the exhibition site. No nails should be used in the floors, beams, or ceilings. No objects should be suspended from the ceilings. And fire protection facilities and plumbing should not be blocked. If there is any violation of these regulations, TAITRA retains the right to immediately remove the entire structure.
- (15) After TAITRA has granted written approval for the construction of second-story booths, any alterations in booth design without prior approval or violation of these Guidelines will result in a suspension of electricity and closure of booths. TAITRA will also ban the responsible company from participating in all trade shows held in the Taipei World Trade Center Exhibition Hall by TAITRA for the next two years. The booth contractors will also be banned for two years from contracting any projects for TAITRA.
- (16) If the construction and design plan for second-story booths approved and signed by an architect, civil engineer, or structural engineer violates building codes or these Guidelines, or there is negligence of inspection during construction, TAITRA will not accept bids from the responsible architect/engineer for the next two years.
- (17) Areas not covered in these Guidelines should be dealt with according to the Regulations Governing Booth Decoration within Taipei Nangang Exhibition Center, Hall 1.
- (18) Limited to the ceiling height, the constructor should exercise caution to avoid bumping or making contact with the fire sprinklers. For safety reasons, spotlights should not be placed directly below the fire security equipment, including sensors for smoke and heat. If there are any violations of these regulations, TAITRA retains the right to immediately remove the structure at the exhibitor's expense.
- (19) TAITRA retains the right to interpret, or to revise these Guidelines for any oversight or omission.

17. Construction Guidelines for Booths Exceeding 4 Meters

- (1) These Guidelines have been established for the construction of booths exceeding 4 meters. To set up booths exceeding 4 meters, participants in the show must comply with the Guidelines to ensure the safety and overall tidiness of the exhibition site.
- (2) With booth units measuring 3m x 3m, show participants must rent at least 8 units of corner booths with at least 3 sides open or island booths with all 4 sides open in order to be eligible to apply for the construction of booths exceeding 4 meters.
- (3) To apply for the construction of booths exceeding 4 meters in any TAITRA Taipei trade show,



participants must submit the following data along with the deposit of **NT\$10,000** to TAITRA by registered mail prior to **September 27**. Construction cannot begin without prior written approval from TAITRA. The deposit will not be returned for any violation.

- One copy of the **Application Form (please have your constructor to submit the application)**
 - One copy of the booth layout plan
 - One copy of the construction plan (including plan, elevation and side drawings with specific dimensions, a list of the building material, and indications of the floor load with maximum number of people allowed on the second floor), the structure plan and structure calculation report, all of which must be approved and signed by a licensed architect, civil engineer, or structural engineer, and have a scale of no less than 50:1.
 - A copy of the architect, civil engineer, or structural engineer's license, certificate, and letter certifying membership from the related professional association, as well as the safety confirmation report on booths exceeding 4 meters.
- (4) TAITRA will charge an "Exceeding fee", which is **NT\$100,000** (tax included) **within 18 square meters**. Those who exceed 18 square meters will be charged in proportion to the addition. Moreover, the exhibitor is required to rent eight or more booths before being permitted to build structures that exceed the maximum allowed height. Fixtures or signs that are affixed above the main (2.5m) structure should be recessed at least 100cm from the side edge of the lower structure between booths.
 - (5) After obtaining construction approval from TAITRA, the applicant must purchase accident and third-party liability insurance of no less than NT\$2,000,000 for each person and each accident. Insurance should cover the show period and include the events move-in to move-out days. A copy of the insurance policy should be sent to TAITRA ten days prior to the move-in day, before construction begins.
 - (6) The architect, civil engineer or structural engineer who has approved the construction plan, or the designated deputy, should inspect on site the construction and dismantling of booths. Upon completion of construction, the architect must issue a certificate of completion to ensure that the booths have been constructed in accordance with the plans, and that safety is guaranteed.
 - (7) The height of the booths exceeding 4 meters must not be more than 6 meters. The recessed distance between booth unit boundary lines, and the front and sides of the main body of the booths exceeding 4 meters should be maintained at 100cm, and the exterior of the walls should be decorated.
 - (8) The construction of the booths should not present any hazard to the exhibition site. No nails should be used in the floors, beams, or ceilings. No objects should be suspended from the ceilings. And fire protection facilities and plumbing should not be blocked. If there is any violation of these regulations, TAITRA retains the right to immediately remove the entire structure.
 - (9) After TAITRA has granted written approval for the construction of booths exceeding 4 meters, any alterations in booth design without prior approval or violation of these Guidelines will result in a suspension of electricity and closure of booths. TAITRA will also ban the responsible company from participating in all trade shows held in the Taipei World Trade Center Exhibition Hall by TAITRA for the next two years. The booth contractors will also be banned for two years from contracting any projects for TAITRA.



- (10) If the construction and design plan for booths exceeding 4 meters approved and signed by an architect, civil engineer, or, structural engineer violates building codes or these Guidelines, or there is negligence of inspection during construction, TAITRA will not accept bids from the responsible architect/engineer for the next two years.
- (11) Areas not covered in these Guidelines should be dealt with according to the Regulations Governing Booth Decoration within Taipei Nangang Exhibition Center, Hall 1.
- (12) The constructor should take most care not to bump or make contact with fire sprinklers. For safety reasons, spotlights should not be placed directly below fire security equipment, including sensors for smoke and heat. If there are any violations of these regulations, TAITRA retains the right to immediately remove the structure at the exhibitor's expense.
- (13) TAITRA retains the right to interpret, or to revise these Guidelines for any oversight or omission.

18. Wall Television/Sound System& Stage Equipment Setup

Deadline : September 6, 2019

(1) Televisions or Big Screens over 5m²

Regulations for setting televisions on walls :

- A deposit of **NT\$10,000** will be requested upon approval of the application. Electricity will be disconnected if the deposit of **NT\$10,000** is not received by the organizer.
- Walls must not exceed 2.5 meters in height.
- The front of the wall must be at least one meter from the edge of the aisle or maintain an angle of at least 30 degrees with respect to the aisle.
- The volume of the films or videos must not exceed 85 decibels.
- Films or videos played must be related to the products or services of the exhibitor. NTSC is the universal video system used in Taiwan.

(2) Stage Equipment

Regulation for setting Stage Equipment

- A deposit of **NT\$10,000** with the **booth layout** and **construction plan** will be requested upon approval of stage equipment. Electricity will be disconnected if the deposit is not received by the organizer.
- The organizer will return the check without interest after the show if all regulations are followed. Otherwise, the deposit will be confiscated.

(3) Sound System

Regulation for setting Sound Systems

- A deposit of **NT\$30,000** with the **booth layout** and **construction plan** will be requested upon approval of sound system. Electricity will be disconnected if the deposit is not received by the organizer.
- Anyone found, during the show period, using a sound system without approval will have to make apply and place a deposit of **NT\$10,000**, in addition, the applicant has to pay **NT\$30,000** fee for using the sound system. Electricity will be disconnected until the procedure is completed.
- Whenever it is found that the volume of the exhibitor's sound system exceeds **85 decibels**, the inspection group will determine the penalty. Generally this will be in accordance with



the following steps: First, there will be a fine of **NT\$1,000**; Second, a fine of **NT\$4,000**; Third, a fine of **NT\$10,000**; Forth, a fine of **NT\$15,000**; Fifth, the power will be disconnected.

- The organizer will return the check without interest after the show if all regulations are followed. Otherwise, the deposit will be confiscated.

Contact:

TAITRA, Exhibition Dept.

Ms. Jill Chiu

Tel: 886-2-2725-5200 ext. 2684

E-mail: taitronics@taitra.org.tw

19. Regulations Regarding Use of the Promotional Balloons

Any exhibitor wishing to use BALLOON at their booth should note the following conditions:

- **Large promotional balloon :**

1. Only one balloon per exhibitor can be used at each exhibitor's booth.
2. The balloon should only carry the company's name, logo or product brand name.
3. The top of the balloon should not be higher than 5 meters from the floor.
4. To apply for a promotional balloon (with the balloon's diameter less than **2 meter** in width), exhibitors are required to deposit **NT\$10,000** security deposit which will be refundable after the show if no violation occurred. For balloons exceeding 5 meter and less than 7 meter in height, exhibitors are required to deposit **NT\$10,000** and to pay an additional **non-refundable fee of NT\$10,000**.

- **Small non-flying balloons**

1. To be used for booth decoration.
2. The top of the balloons should not be elevated higher than 4 meters from the ground floor.
3. No fee is required.

Note:

1. All balloon(s) must use only helium or nitrogen and must be properly fastened to the booth(s).
2. Those wanting to use large promotional balloon should submit the appropriate **Application Form** before **September 6, 2019** along with a deposit of NT\$10,000. An additional non-refundable fee of NT\$10,000 is required for balloons raised over 5 meters but less than 7 meter in height.
3. For every exhibitor violation of above regulations, a NT\$10,000 penalty will be deducted from the exhibitor's balloon deposit.
4. **All filled balloons will be measured by the organizer.** TAITRA will remove improper balloons raised without permission.

Contact:

TAITRA, Exhibition Dept.

Ms. Jill Chiu

Tel: 886-2-2725-5200 ext. 2684

Fax: 886-2-2725-3501

E-mail: taitronics@taitra.org.tw



20. Regulations on Work at TAITRA Venues

Chapter 1: General Provisions

- I. As per the agreement signed with the Ministry of Economic Affairs, Taiwan External Trade Development Council (TAITRA) will manage and operate the Taipei World Trade Center Exhibition Hall (hereinafter referred to as "TWTC Exhibition Hall 1"), the Taipei International Convention Center (TICC), and Taipei NANGANG Exhibition Center Hall 1 (hereinafter referred to as "NANGANG Exhibition Hall 1"). TAITRA will also manage and operate the Taipei World Trade Center Exhibition Hall 3, as per the agreement signed with the National Property Administration. For the purpose of management, TAITRA has established the Exhibition Hall Decoration Construction Regulations and applicable attachments by which leaseholders, decoration contractors and exhibitors are to follow. Regulations including but not limited to various types of forms (hereinafter referred to as "these regulations").
- II. Excluding special situations which require additional regulations, regulations stated within shall be applicable to indoor and outdoor decoration work for all areas described above.
- III. These regulations shall become effective upon receiving the approval from TAITRA's secretary general, and their implementation starts on the announcement date. Revisions will follow the same procedure. Unless otherwise specified or approved by TAITRA with a written consent that old regulations can be used within a specific period of time, leaseholders and decoration contractors must abide by the latest revision of these regulations for their decoration work, and they must be responsible for the latest announcements associated with these regulations.
- IV. Except for decoration contractors who work under special regulations, leaseholders shall be responsible for any violation of the regulations, as well as any compensation or restitution. Leaseholders shall incorporate these regulations into exhibitors' contracts and guarantee all exhibitors will follow these regulations during the exhibition event.
- V. Unless otherwise specified, all booth decoration work at TAITRA managed exhibition halls shall comply with these regulations. The laws of R.O.C. shall supplement any questions or inadequate definitions to these regulations, and TAITRA reserves the right to final interpretation.

VI. Definitions of the regulations:

- (I.) *Leaseholder*: Exhibition or event organizer.
 - (II.) *Decoration contractors*: decoration contractors include but are not limited to human resource agencies, carpenter, art designer, painting, carpeting, plumbing, audio systems, lighting, transportation, steel work, forklift operators and customs.
 - (III) *Management unit*: Refers to TAITRA's internal unit that is in charge of the operation and management of different exhibition halls.
- VII. To allow all decoration construction workers who have access to the exhibition halls to fully understand and abide by the safety regulations and regulations regarding decoration work, in order to protect the safety of workers and exhibition hall facilities, TAITRA requires that all decoration construction workers must receive training in "TAITRA Exhibition Hall Construction Safety" and receive a TAITRA class certificate before applying for the "TAITRA Exhibition Hall Service Permit". Workers who do not have a service permit are denied access to the exhibition halls. For more details on the application procedure for a TAITRA class certificate and the Exhibition Ground Service Permit, please see the enclosed attachment.

Chapter 2: Occupational Safety & Health Matters

- I. To prevent injuries on the job and protect worker safety, leaseholders must follow the Vocational Health and Safety Act, the TAITRA Letter of Undertaking for Pre-Construction Safety and Health, Regulations for TAITRA Project Contractor Pre-Construction Operation Standard, TAITRA Contractor Health and Safety Management Regulations, the TAITRA Delivery and Contract Hazard Notice Form and the TAITRA Construction Site Hazard Notice Form.
- II. TAITRA's applicable health and safety regulations can be downloaded from the following website:
<http://www.twtc.org.tw/content/E/E3b.asp>

Chapter 3: Regulations for Booth Decoration

I. Design and Structure:

1. The maximum height of each booth is 2.5 meters (display items and space between booths included), and the height of signs can be up to 4 meters. The length of booth walls must be less than half the length of booth frontage with the length of sealed walls not exceeding 9 meters.
2. Exhibitors who require two-story booths must submit their application forms and pay the corresponding fee in advance according to the rules for two-story booths. Two-story booths are not allowed on the 2nd floor of TWTC Exhibition Hall 1 and in TWTC Exhibition Hall 3.
3. Under special conditions, if exhibitors must construct extra-high structures (higher than 4 m and less than 6 m), the leaseholder must submit the affidavit for those exhibitors, a copy of the public liability insurance, third-party liability insurance and the structure design/location design blueprints to the management unit and agree to pay the fee for extra-high structures 10 days before the exhibition. Only exhibitors who rent more than four booth spaces are permitted to construct extra-high structures, and the height of each structure cannot be more than 6 meters; its periphery must decrease by 1 meter from the edge of the walkway. The fee for extra-high structures is calculated according to the area of the view projection on the blueprint, and is NT\$100,000 per 18 square meters (tax included). If the area exceeds 18 square meters, the fee is charged by the area of view projection on the extra-high structure blueprint divided by 18 square meters/unit, and then multiplied by NT\$100,000. If the



construction area is less than 18 square meters, the fee is still NT\$100,000.

4. The use of public areas is strictly controlled (areas such as the main entrance, lobby, sidewalks, plaza, rest areas, underground parking, unloading yard, and freight elevators) and exhibitors are prohibited from placing in these areas any materials like stands, exhibition billboards, flag poles, advertisements, posters or flower baskets. (With the exception of leaseholders who have applied for, paid for, and received permission from the relevant management unit)
5. The area of booth decoration cannot be more than half of the booth's total sealed area.
6. **Special Regulations for Nangang Exhibition Center, Hall 1:** The top opening of each booth (two-story booths included) cannot be covered with curtains or wooden boards. If there are any special decoration needs, leaseholders should submit an application to get the permission for special decorations from the management unit.
7. **Special Regulations for TWTC Exhibition Hall 1:**
 If there is a need for display effects, the top opening of the booth at the central courtyard of the first floor (Area D) (two-story booths included) can be enclosed with curtains or wooden boards.. If it is necessary to install a ceiling, then it is required to be visually appealing from all sides. Such space cannot be used to store objects.
8. The booth's structure, display items, and decorations such as signs, flags, plants, rugs and overhead lights cannot exceed the area that is outside the space perpendicular to the ground.
9. No objects can be hung from the ceiling or pipelines, and no posters/advertisements are permitted on the columns. If a particular violation has not been resolved after a warning has been issued, TAITRA has the right to remove these objects, and the leaseholder is responsible for any fees incurred by the removal.
10. **If an exhibition booth includes all or part of a column, the exhibitor must fill out the Column Decoration Application Form along with a booth design blue print (floor and elevation plan) and submit them to the organizer** at least 25 days before the exhibition. After exhibitor list is compiled the organizer must submit an application at least 15 days before the exhibition. Once construction permission is issued, exhibitors may begin to decorate the column. **Instructions for decorating columns:** If walls are added to columns, they must have suitable openings for fire alarms, sprinkler switches, fire extinguishers, circuit boxes, and grounding plates, and no insulation wall or objects can be placed in front of the items listed above. The height of temporary walls for columns shall not be more than 4 meters. If any of the above regulations have been violated, the wall shall be torn down and the leaseholder/exhibitor must pay for the dismantling cost. Failure to conform to the construction regulations with no rectification may lead to a fine from the fire department. If a fine has been issued, the leaseholder/exhibitor shall be responsible for its payment and all related responsibilities.
11. **Special regulations for Nangang Exhibition Center, Hall 1:**
 There are eight display booth areas separated by 6.1 meter-wide walkways on the ground floor of the exhibition hall and the Sky Dome Exhibition Hall (walkways must be more than 7.4 meters wide for car exhibitions). The area for each booth section cannot be more than 3,000 squares meters.
12. **Special regulations for the Taipei International Convention Center:**
 - (1) Access to events or exhibitions held at the rest areas on the south and north sides of the TICC should use the west entrance. Signs and product logos displayed in this zone should have a maximum height of 2.5 meters, except for those on the side with air conditioning units. The height for other sides may reach 4 meters, and raised parts should be set up 0.5 meters away from the outer edge. The minimum distance between decoration and this section's air conditioning units should be 80 cm.
 - (2) Flags and flagpoles are forbidden at TICC's main entrances, light posts around the perimeter, and sidewalks. Promotional stands are only allowed on the southern and northern areas outside the eastern gate, and their height is limited to 4 meters. Their design and dimensions must first be approved by the management unit, and only then can they be set up.
 - (3) Measurement restrictions for event billboards set up between the escalators on both sides of the TICC lobby are 4 meters tall and 5 meters wide. The position of the billboards cannot be more than 70 centimeters from the wall and no objects can be attached to the surface of the wall.
 - (4) Hanging banners on the north and south sides of the lobby cannot exceed 1.5 meters in width and 4.5 meters in length. There are a total of 22 flagpoles outside the TICC by the fountain located at the southwest corner of the Center. Only size 8 flags are suited for these poles (measuring 240 cm in width x 160 cm in length). Exhibition hall leaseholders shall submit the design of flags to the management unit for review prior to the exhibition; the flags can be raised once approval has been received.
 - (5) If posters or fliers need to be posted around the conference room or on the walls of public areas, the location and methods of display shall comply with the regulations established by TICC. The use of tacks, pins, double-sided tapes, and Velcro is strictly prohibited, and the posting party is responsible for taking down everything and returning the walls back to their original condition. Regulations for hanging locations and hanging methods are as follows (please see and download detailed illustrations and explanations from the TICC website)
 (Chinese) <http://www.ticc.com.tw/Content/Download/index.aspx?PType=0&lang=zh-tw&Sort=13>
 (English) <http://www.ticc.com.tw/Content/Download/index.aspx?PType=0&lang=en-us&Sort=13>
 - (6) First floor north and south lobbies and first floor corridors have dedicated ceiling flag hanging rails installed; hanging rails are installed 5.6 meters above the floor at the west main stage of meeting room 101; hooks are installed at 3.8 and 4.5 meters above the floor and are placed at 1.29 meter intervals. On the ceiling of the divider screen area, hooks are



installed at 1.29 meter intervals.

- (7) An electric curtain is installed on the main stage of meeting rooms 102 and 103, and a flag hanging rail is installed between the seams of the wallpaper (upper) and textile wall covering (lower) at approximate 2.95 meter intervals.
- (8) North and south lobbies on the 2nd floor have flag hanging rails installed on the ceiling. The setup of meeting room 201 is identical to meeting room 101. If pearl boards are used to make posters, it is recommended to make holes 1.29 meters apart have them strengthened with wood strips to prevent the boards from breaking.
- (9) Tape can be used on the aluminum frame of the divider screen. Pay close attention when removing the tape to prevent adhesive residue and return the divider screen back to its original state.

II. Special decorations and facilities:

1. TV wall and large screen wall:

If TV walls, large screen walls, or other facilities are required, please follow the regulations listed below:

- (1) If the installation is less than 2.5 meters in height, the front shall be at least 1 meter away from the booth's baseline, or it shall be set at a 30 degree angle to the booth's baseline.
- (2) If the installation is higher than 2.5 meters, the total height shall not exceed 4 meters, and the front of the installation shall be recessed by at least 2 meters from the booth's baseline, or it shall be set at a 30 degree angle to the booth's baseline.
- (3) Videos being shown shall correspond to the theme of the exhibition or event, and shall not violate good moral standards.

2. Tethered balloons:

- (1) If there is a need to install tethered balloons within the vertical extended area of the booth baseline, an application must be submitted to the management unit and corresponding fees must be paid 10 days prior to the exhibition. Balloons raised without proper permission will be promptly and physically removed, and the dismantling cost shall be borne by the leaseholder. Tethered balloons shall only be set up within the booth area, and they shall be secured in place so they do not float around. The maximum height of large advertising balloons shall not exceed 7 meters from the top of the balloon to the ground. Large balloons that are more than 5 meters above the ground require payment of a fee of NT\$10,000 per balloon; balloons that are less than 5 meters from the ground are free of charge. The top of small decorative balloons cannot be higher than 4 meters from the ground. If balloons are floating on the exhibition hall ceiling, or if strings are hanging from the pipelines on the ceiling, they must be removed before leaving the site, otherwise a fine of NT\$10,000 per balloon/string will be issued. The leaseholder is liable for all legal responsibilities and damage compensation for accidents caused by tethered balloons.
- (2) Special regulations: Tethered balloons shall not be used in the TICC Plenary Hall, second floor H area of TWTC Exhibition Hall 1 and TWTC Exhibition Hall 3.

3. Stage and sound equipment:

Stage and sound equipment set up in a booth shall comply with the following regulations:

- (1) The edge of the stage shall be at least 2 meters back from the baseline of the booth, and the loudspeaker shall face inward towards the booth, with speakers angled downward. Sound volume shall be maintained below 85 decibels, and adjacent booths cannot conduct events on stage or simultaneously use the loudspeakers.
- (2) The leaseholder shall require all exhibitors to abide by the aforementioned regulations. With respect to violators, the management unit will issue fines to the leaseholder pursuant to the following provisions.
- (3) Violations will be processed in three stages:

Stage 1: If the volume of the loudspeaker exceeds the specified decibel level or the exhibitor violates other regulations and does not make immediate rectification following verbal warning, a warning ticket will be issued with a note stating that a fine will be issued if repeated violation is found.

Stage 2: If a violation has not been improved after additional review, a fine will be issued based on the number of offenses: NT\$1,000 for first time offenders, NT\$4,000 for second time offenders, NT\$10,000 for third time offenders, NT\$15,000 for fourth time offenders, and NT\$20,000 for fifth time offenders.

Stage 3: For exhibitors who refuse to make improvements and have been fined five times, TAITRA will stop providing electricity for the violating booth.

4. Wireless microphone equipment:

Leaseholder must apply to the management unit for approval for the maximum microphone level and set up the microphone only after receiving approval. If a microphone is used in violation without proper approval and interferes with other activities, TAITRA will request the violator to stop using the equipment immediately, as well as handle the violation pursuant to the three stages listed above.

III. Utility Installation Management:

1. Those with booths requiring water and electricity shall submit an application to the leaseholder who will submit a consolidated order to the management unit. Power supply will be cut off to those accessing power without proper authorization with violators be prohibited from exhibiting during the event. Any decoration contractor who has violated this provision will have their registration revoked.
2. Compressed air and ceiling lighting will be provided for booth decorations and furnishings to match opening hours during booth set-up (with the day before exhibition is excluded). However, electricity will not be provided for the booth, if decoration contractors have other requirements for electricity, the decoration contractor can request for electricity from the leaseholder at



the service counter, and TAITRA will supply electricity based on the time period requested.

3. Anyone who applied for utilities (including 24-hour utility provision) shall install protection back up measures on their own accord (i.e. for assured uninterruptible power). Note that if there is a power outage (including water outage) from the Taiwan Power Company, or in the event of a utility equipment breakdown at the exhibition hall, TAITRA shall not be held responsible.
4. Booth lighting and lighting equipment must be provided and installed by electrical and plumbing contractors with a Level A or higher Electrical Appliance Installation Certificate, as well as completed their registration with TAITRA's related agencies. Exhibitors are strictly prohibited from bringing in their own lamps for installation (with the exception of lamp/lighting exhibitions). Power supply will be cut off for violators, and violating booth holders will be prohibited from exhibiting. If public danger, property damage, or personnel injury has occurred, the leaseholder and the violating exhibitor shall be jointly responsible for compensation and legal responsibility.
5. To prevent equipment overload or defective equipment from causing accidents such as circuit breaker tripping and electrical fire, it is strictly prohibited to dismantle and damage exhibition hall electricity supply facilities, or to connect electrical appliances that are not compatible with the exhibition hall's electrical equipment. Equipment in violation will be removed, and the cost for removal will be borne jointly by the exhibitor involved and the decoration contractor. Power supply will be terminated to the non-compliant booth.
6. Neon lights, flickering, pulsing, or spinning strobe lights, as well as string lights are not to be installed (display items inside the booth are excluded). Power supply to non-compliant booths will be cut off if violators do not make improvements upon receiving notification. All lighting equipment shall not face upward to prevent objects from falling on the lampshade and starting a fire, causing danger.
7. Electrical wiring grooves inside TAITRA's exhibition halls are for wiring purpose only. To prevent circuit breakers from tripping and electrical fire, it is strictly prohibited to discharge water into the wiring grooves.
8. Without TAITRA's permission, exhibitors cannot install air conditioning equipment inside the booths; a warning will be issued to the exhibitor and the leaseholder will be requested to remove such equipment within two hours. If the equipment is not removed within two hours, the violator will be fined NT\$10,000 (tax included), and the electrical wiring of the air conditioning equipment will be removed. The resulting expenses and the corresponding fine shall be deducted from the security deposit paid by the leaseholder. If the installation of air conditioning equipment is required inside a booth, a written application shall be submitted to the leaseholder prior to the exhibition. The leaseholder shall submit the applications collectively seven days prior to the exhibition, and only after TAITRA has issued an approval form in writing, can the equipment be installed.
9. In order to promote safe use of electricity, the leaseholder, exhibitors and decoration contractors shall comply with the following three-level electricity usage control measures:

(1) First level, self-management:

Electrical and plumbing engineers with Level A Electrical Appliance Installation Certificates shall conduct self-managed electrical safety inspections at exhibition booths during the setup period. A self-management inspection form shall be submitted to the management unit two hours prior to the transferring of electricity or one day before the setup period ends. Electricity will be temporarily shut off at booths that do not complete and pass the electrical safety inspection and remain off until the inspection is completed or the deficiency has been corrected.

(2) Second level, supervising unit inspections:

Before electricity is connected, management's electrical and plumbing maintenance contractor and TAITRA electrical engineers shall complete the electrical safety inspection. Booths that fail to pass inspection will not be supplied with electricity, and an Improvement Notice will be posted. After the booth completes the necessary improvements and is re-inspected and verified by management unit, electricity will only then be supplied to the booth.

(3) Third level, third-party inspections:

Electrical appliance inspection and maintenance vendors shall designate personnel to inspect electrical facilities such as the transformer substation and exhibition hall's electric switch boards on the day electricity is to be connected.

IV. Fire safety management:

1. If a single level booth is designed with a ceiling to seal the top, or if a two-story booth (regardless if the top is sealed or not), the booth shall be equipped with at least two 10P ABC dry chemical fire extinguishers.
2. **Special regulations for Nangang Exhibition Center, Hall 1:**
 Pursuant to Article 11 of the Fire Services Act, booth decorations used in the entire exhibition hall shall be made of materials indicated as flameproof; relevant materials including carpet, curtains, cloth screens, advertisement boards used during the exhibition, and other objects must be designated as flameproof. A flameproof marker shall be affixed to a visible corner of the item that has been verified by a specialized agency. Exhibitors shall prepare valid documents of proof to certify their materials are flameproof, as references by the fire department from the day they start the decoration work to the end of the exhibition. If these regulations are violated, causing TAITRA to receive a fine or incur penalty, the violating leaseholder and/or exhibitor shall bear full responsibility (for regulations and details regarding flameproof materials. (See: **Nangang Exhibition Hall Booth Decoration with Flameproof Materials**).
3. **Special Regulations for TWTC Exhibition Hall 1:**
 Unless otherwise approved by TAITRA, the use of wooden decorations on the second floor of TWTC Exhibition Hall 1 is prohibited, and exhibitors shall use flameproof and environmentally friendly decoration materials which can be assembled,



recycled, or reusable. The second floor of TWTC Exhibition Hall 1 must be decorated by one unified, commissioned decoration contractor.

Regulations for leaseholders using gas or fire:

- (1) Use only gas tanks that have passed inspection; each booth shall prepare at least two fire extinguishers (10P).
 - (2) Apply for public liability insurance, the insured amount shall not be less than NT\$64 million, pursuant to Taipei Commercial Property Compulsory Public Liability Insurance Implementation Regulations.
 - (3) An Exhibition/Event Safety Proposal (including an emergency evacuation plan) must be submitted for approval to TAITRA for review, and then to the Taipei City Fire Department 2nd District HQ.
 - (4) A breaker for the gas supply shall be installed.
 - (5) Total weight of gas for each exhibitor shall not exceed 80 kg (including backup gas).
 - (6) Complete TAITRA TWTC Exhibition Hall 1 and Exhibition Hall 3 Fire Usage Safety Affidavit (see Appendix 3) and submit form to management unit.
4. The sealing of electrical distribution boxes, fire protection equipment, fire exits, and safety signs is prohibited. Blocking stair cases and traffic flow with decorations, materials, or display items is strictly prohibited. If a violator does not rectify the situation after receiving notice, management will immediately remove the offending object, and the leaseholder shall bear all expenses incurred.

V. Painting:

1. Painting in the exhibition hall must be done with water-based paint.
2. Painting crews are responsible for cleaning masking tape scraps that are still attached, which shall be gathered and discarded in the trash.
3. PVC cloth or plywood shall be placed on the floor before painting, so that paint does not stain the floor.
4. Dumping leftover paint into bathroom sinks or toilets is strictly prohibited; instead, painting equipment shall be washed in designated washrooms. Those leaseholders found in violation will be held responsible for all cleaning and expenses incurred.

VI. Carpeting:

Installing carpets by spreading adhesives on the floor is strictly prohibited. To install carpeting, non-residue tape shall be placed on the floor, along the wall and 10 centimeters from the wall to secure the carpet to the floor. Double-sided carpet tape shall be placed on top of the non-residue tape to secure the carpet.

VII. Other

1. Water, flower, and meal delivery personnel are prohibited from entering the exhibition hall to solicit sales.
2. The use of steel nails, spray paint, arc welding and chainsaws is strictly prohibited within the exhibition halls.
3. Construction wastes and packaging materials shall be disposed of daily and shall not be placed on walkways, obstruct traffic or create a safety hazard. The leaseholder is responsible for disposing wastes that were not removed in time and all associated costs. The leaseholder shall be responsible if waste is not disposed of in time and remains in a spot which affects the construction process.
4. The use of fuel-burning electric generators is prohibited inside the exhibition hall.

Chapter 4: Site Access Control

I. Traffic control:

1. Electric or LPG forklifts that weigh 2.5 tons or less may enter the exhibition halls for operation. But diesel forklifts are prohibited inside the exhibition halls (with the exception of machinery exhibitions).
2. When trucks enter exhibition halls, a security deposit of NT\$1,000 shall be paid at the entrance (deposit amount is higher for machinery or large scale exhibitions). The full amount of the deposit will be returned to vehicles that leave the exhibition hall within 1 hour. NT\$200 will be collected for each additional unit-hour a vehicle stays beyond the designated time (time is counted from when the vehicle enters the exhibition hall). If a vehicle's exit time is delayed due to traffic congestion inside the exhibition hall, after receiving the seal of a security guard hired by TAITRA as proof, a lateness period of 20 minutes will be waived.
3. Small passenger cars are prohibited inside the exhibition halls; vehicles that have entered the exhibition hall must turn off their engines once they have arrived at their destination. Speed of vehicles in the hall must not exceed 10 km/hour.
4. **Special regulations for TWTC Exhibition Hall 1 and Hall 3:**
 - (1) The maximum load capacity of Exhibition Hall 1's ground floor is 1,300 kg/m². Exhibits or decorations that exceed the weight limit must be dismantled and packaged separately before they enter the exhibition halls. Those that cause damage to the facility due to improper handling shall be liable for compensation.
 - (2) No vehicles shall pass through the post office or the front of the glass elevator areas.
 - (3) **Relevant load capacity limits are listed below:**

Regulations regarding the ground floor load capacity of TWTC Exhibition Hall 1, and vehicles entering/exiting the exhibition hall	
1. Floor load capacity limit (exhibits)	Must not exceed 1.3 tons per square meter.



2. Load restrictions for vehicles (including combined weight of vehicle and goods)	(1) Dual-axle vehicles must not exceed 15 tons; vehicles with more than two axles must not exceed 25 tons. (2) The minimum safe distance between two vehicles is 9 meters.
3. Load restrictions for forklifts	(1) Total load for an individual forklift must not exceed 13 tons. (2) When two adjacent forklifts are lifting different objects, the two vehicles should maintain a distance of at least 9 meters.
4. Load restrictions for crane trucks	(1) An individual crane's total load should not exceed 15 tons; when two adjacent cranes are handling different objects, they should not be closer than 9 meters. (2) Wooden boards or steel plates must be used underneath load supports as padding, and the dimension of the padding must not be less than 30 cm (length) x 30 cm (width) x 15 cm (height).

- (4) Vehicles with a total weight of more than 15 tons (determined by the weight indicated on the vehicle or on vehicle registration) shall submit a written application to TAITRA through the event organizer five days before entering the site. Crane trucks of any capacity (including derrick trucks) shall submit an application to the TAITRA Exhibition Hall Management Division two business days in advance before entering the exhibition hall. If a vehicle with a total weight of more than 15 tons is loaded with cargo, a proof of weighing issued within the last 24 hours is required and must be accepted by the management unit of Exhibition Hall 1 before entry is permitted. Only if and when such proof is accepted will the vehicle be allowed to enter the site for operation within the allocated time period.
- (5) **Limit for the number of diesel forklifts:** In principle, TWTC Exhibition Hall 1 can only accommodate up to four forklifts working simultaneously (the central atrium, Area D, allows up to two forklifts to operate simultaneously).
- (6) The entrance of TWTC Exhibition Hall 1 is 4.2 meters high and 7 meters wide; the entrance of TWTC Exhibition Hall 3 is 5 meters high and 6.5 meters wide (however, the exhibition area of Exhibition Hall 3 is 4.47 meters high). Trucks, exhibits, or decorations that exceed these dimensions must be dismantled and packaged separately before entering the exhibition hall. Those that cause damage to the facility due to improper handling shall be liable for compensation.
- (7) Method of payment for air pollution control admission fee for crane operations (including derrick trucks):
- i. Entry during work hours (6AM to 7PM during business days):
Applicants must fill out the Crane Truck (including derrick trucks) Operation Application Form and submit it to the Taipei International Exhibition Center, Exhibition Hall Management Division at least two business days before entering the exhibition hall. A security deposit of NT\$2,000 is required when entering the site (deposit amount is higher for machinery or large scale exhibitions). The vehicle operator must connect the adapter and the aluminum ducts provided by security to the vehicle's exhaust pipe, and then return them to security upon completing their work.
The aforementioned air pollution control charge is NT\$500 for the first hour and NT\$300 for each additional hour. Charging starts when a vehicle enters the exhibition hall and ends upon its exit. If the time is less than 1 hour, it is calculated as 1 hour. If the entry application is submitted to the management division less than 2 business days in advance, an additional 50% charge will be added to the charges listed above.
 - ii. Operation during non-business hours (national holidays, and after 7PM and before 6AM on business days): Air pollution control charges will be waived; however, vehicle exhaust redirection shall still be conducted and security fees shall still be paid.
 - iii. If there are too many applications, or if other concerns arise, TAITRA has the right to adjust times or dates, or reject applications.
- (8) If grapple trucks are required, the leaseholder should apply in advance. The operation of grapple trucks is limited to areas A, B, and C of TWTC Exhibition Hall 1. It is strictly prohibited for these to operate in Area D and around the main access areas of the exhibition hall. Operation time of the grapple truck inside the exhibition hall is after 7PM and before 06AM on business days. There are no restrictions on operating times on weekends. However, the organizer should take into consideration the time required for preliminary work such as removal of water and electricity items as well as carpets. Exhibition and event organizers shall submit the TWTC Exhibition Hall 1 Grapple Truck Entry Application Form to the management unit five days prior to the entry of the grapple truck. TAITRA may reject or approve the application based on safety concerns. The World Trade Center Exhibition Hall 1 only allows up to 4 grapple trucks at any given time. Previously stated provisions for exhaust emissions and cost of security personnel shall apply.
- (9) Cranes trucks and grapple trucks are not allowed to operate in the TWTC Exhibition Hall 3.
5. Special regulations for Nangang Exhibition Center, Hall 1:
- (1) Exhibition hall (vehicle entrance from Jingmao 1st Road). To reach the Sky Dome Exhibition Hall, vehicles must go up



through the truck ramp (also known as the curved ramp with a total width of 11.4 meters and height of 6 meters. Vehicle height limit is 4 meters).

(2) The height and width of cargo entrances at each area are:

- Area I: 5 meters high, 9.9 meters wide
- Area J: 4.5 meters high, 11.6 meters wide
- Area K: 5 meters high, 10 meters wide
- Area L: 4 meters high, 11 meters wide
- Area M: 8.5 meters high, 11.9 meters wide
- Area N: 4 meters high, 10.1 meters wide

The vehicle's height limit for the entire first floor exhibition hall and the Sky Dome Exhibition Hall is 4 meters. If total height of a vehicle or its cargo exceeds 4 meters, an application must be submitted to the management unit (including 4.25 meter extra height container trucks). Only after receiving approval can a vehicle enter the site and only by taking the designated routes.

(3) The maximum load capacity of the exhibition hall's first floor is 5 tons/m², and the maximum load capacity of the Sky Dome Exhibition Hall floor is 2 tons/m². Vehicles or cargo that exceed the width of the cargo entrance or the freight elevator door, or surpassed the height restriction of the curved ramp are prohibited from entering the exhibition hall. Exhibit and decoration loads that exceed the weight limit must be dismantled and packaged separately before entering the exhibition hall. Those that cause damage to the facility due to improper handling shall be liable for compensation.

(4) **Load capacity regulations for vehicles entering/exiting the exhibition hall:**

Ground floor (including entrance driveway)	
1. Vehicle load restrictions (including the combined weight of vehicle and goods)	(1) 20 tons for dual-axle; 43 tons for those with more than two axles. (2) Minimum safe distance between two vehicles is 6 meters.
2. Load restrictions for forklifts	(1) An individual forklift's total load should not exceed 18 tons. (2) When two adjacent forklifts are handling different objects, they should maintain a safe distance of at least 6 meters. (3) For objects weighing between 18 and 36 tons, two forklifts are allowed to work in conjunction, provided that they maintain a safe distance of at least 4 meters. (4) Each loading and unloading shall not exceed 50 minutes.
3. Load restrictions for cranes	(1) An individual crane's total load must not exceed 27 tons; when 2 adjacent cranes are handling different objects, they should maintain a safe distance of at least 9 meters. (2) For cranes with a maximum load of less than 18 tons, a wooden board (at least 15 cm in thickness) or a steel plate (at least 1.5 cm in thickness) must be used in advance to provide padding for the load support. For cranes with a maximum load of more than 18 tons, a wooden board must be used to pad the load support. The padding material should not be less than 90 cm (length) x 90 cm (width) x 15 cm (height). (3) Each loading and unloading shall not exceed 50 minutes.
Sky Dome Exhibition Hall (includes ramps and unloading platforms)	
1. Vehicle load restrictions (including the combined weight of vehicle and goods)	(1) Maximum of 15 tons for dual-axle, 35 tons for those with more than two axles.



	(2) The minimum safety distance between two vehicles is 6 meters.
2. Load restrictions for forklifts	(1) An individual forklift's total load should not exceed 8 tons. (2) When two adjacent forklifts are handling different objects, they should maintain a safe distance of at least 6 meters. (3) For goods weighing between 8 and 16 tons, two forklifts are allowed to work in conjunction, provided that they maintain a safe distance of at least 4 meters. (4) Each loading and unloading shall not exceed 50 minutes.
3. Load restrictions for cranes	(1) An individual crane's total load must not exceed 12 tons; when 2 adjacent cranes are handling different objects, they should maintain a distance of at least 9 meters. (2) For cranes with a maximum load of less than 8 tons, a wooden board (at least 15 cm in thickness) or a steel plate (at least 1.5cm in thickness) must be used in advance to provide padding for the load support. For cranes with a maximum load of more than 8 tons, a wooden board must be used to pad the load support. The padding material should not be less than 90 cm (length) x 90 cm (width) x 15 cm (height). (3) Each loading and unloading shall not exceed 50 minutes.

(5) For trucks with total weight exceeding 15 tons (based on the load indicated on the vehicle or the vehicle license), or crane trucks, forklifts and derrick trucks of any capacity to work inside the exhibition hall, the leaseholder must first submit an application to Nangang Exhibition Center, Hall 1, at least 20 days in advance by filling out the TAITRA Taipei Nangang Exhibition Center, Hall 1 Heavy Vehicle Access Application Form. The weigh bridge slip shall be submitted for Nangang Exhibition Center, Hall 1's approval before giving access to the exhibition hall during the permitted time period.

(6) No grapple trucks are allowed outside the exhibition hall and its perimeter (entrances, sidewalks, squares, unloading areas, and parking lots).

6. Special regulations for Taipei International Convention Center:

(1) Decorative materials should be delivered through the underground parking lot, and only cargo elevators 11, 13, and 14 shall be used for delivery. The dimension and weight of the material shall be within the specifications displayed on each cargo elevator (see graph below). Also, to avoid collisions, proper attention should be paid to the posted different ceiling heights between entrances, exits and corridors.

Elevator number	Length (meters)	Width (meters)	Height (meters)	Load (kilograms)
11	6	2	2.2	4,500
13, 14	2.5	1.5	1.8	1,600

(2) Those requiring the use of balloons for decoration must inflate the balloons with a safe gas (helium or air) and those using flowers should trim them in the B1 pick-up area. When doing floral arrangements on site, plastic tarps should be placed under the flower baskets to cover the entire working area, which should be cleaned afterwards.

(3) The load limit for the exhibition floor is 400 kilograms per square meter, and the height of a booth is limited to 2.5 meters. Walkway between booths should be at least two meters wide.

(4) Carpet should be laid in all exhibition (display) areas, including booths and public passages. All decorations must be confined within the leased area. During construction, the carpet in the construction area should be covered by a protective layer (such as with a PVC tarp). Steel nails are not permitted to be used on the floor.

II. Operation procedures for entering the site

1. All work by on-site decoration contractors should be completed by no later than one day before the exhibition opens. If a contractor cannot finish on schedule, they should apply for an extension to use the area and pay all related fees. If something needs to be adjusted on the day of the exhibition, decoration contractors may only carry lightweight tools and materials for work. Adjustments must be complete before the opening of the show in order to maintain the image of the exhibition and the security of the exhibition hall.



2. Utility contractors must submit a copy of their installation plan to the management unit for reference before any on-site is done, otherwise such work will not be permitted. After receiving permission from the leaseholder, utility contractors must contact the management unit to apply for the approval for electrical wiring between exhibitions. Contractors must also obtain permission from the leaseholder if they wish to enter the site early or work overtime during the lease period.
3. For the exhibition of large machinery or heavy exhibits, carpeting contractors must submit a request to the management unit for permission to enter the grounds early between exhibitions. Contractors may begin laying carpet after obtaining permission, and they need to pay the related utility costs and security fees. Contractors must also obtain permission from the leaseholder if they wish to enter the site early or work overtime during the lease period.
4. If decorations are made mainly of wood, they should be pre-fabricated outside the exhibition hall and transported inside for assembly.
5. For all decoration work, the leaseholders must require exhibitors and decoration contractors to be insured under the contractors' comprehensive insurance or installation insurance, third-party liability insurance, and employers' liability insurance. Leaseholders will be legally liable and held responsible for compensation for any injury, death or facility damage caused by decoration construction work.
6. Those who failed to apply for an Exhibition Hall Service Permit shall apply according to the processes outlined in this document, and obtain the Exhibition Hall Service Permit 15 days prior to the opening of the exhibition.
7. Leaseholders must submit copies of their exhibition work permits to the management unit 3 days prior to site entry to permit security guards at the entrance use them for reference.
8. Decoration contractors should take measure the site before designing and planning booths in order to ascertain the exact positioning and corresponding location of the booth.

III. Operation procedures for leaving the site

1. When tape is used on the floor, care must be taken to assure that all remnants are removed and disposed after the exhibition.
2. Glass products (including booth decorations or display items) must be intact when leaving, and they must be recycled by the decorating contractor. Smashing glass products is not allowed. A fine between NT\$2,000 to NT\$5,000 will be levied on offenders according to the penalties listed below.
3. All exhibition items, decoration materials and waste must be completely cleaned and transported away from the exhibition hall before leaving the site and must not affect the proceeding of subsequent exhibitions. When there is an open day following the closing of the exhibition, all items, materials, and waste may be transported off site during that time, with an additional leasing fee.
4. Special regulations for Nangang Exhibition Center, Hall 1: according to Taipei Noise Restriction Regulations, grapple trucks operations outside the exhibition hall must finished operations before 10PM. Leaseholders have to consider the length of time needed for set up and site removal, and allocate reasonable and sufficient amount of time for the work.
5. Leaseholders are responsible for requesting their contractors to prepare and install bases and bearings (such as steel beams, steel plates, backing bases or railway sleepers) that can reduce the load burden of concentrated weight of vehicles and cargo if necessary, in order to maintain site safety. Leaseholders are held fully accountable for any damages to the facility as well as any injury caused by the loading operation of vehicles, the cargo they carry, or related matters.

(Note: if any exhibition or decoration item exceeds the maximum height and width of an entrance/exit then it must be dismantled before entry or exit. Those that cause damage to the facility due to improper handling shall be liable for compensation).

Chapter 5: Responsibilities

I. Risk Sharing

1. During the exhibition or event, exhibitors shall assign personnel in monitoring their own exhibits, materials, decorations and construction equipment. Exhibitors should also purchase insurance policies depending on their needs. If items are lost or damaged, TAITRA shall not be held responsible.
2. If due to improper installation, operation, maintenance or management during the exhibition or event (including set up before the exhibition and dismantling after the exhibition), a booth's facilities, objects, or exhibits cause injury, death, or financial loss to the exhibitor's personnel or a third party, the exhibitor and its decoration contractor shall be held fully liable for all compensation and legal responsibility. TAITRA shall not be held accountable. The exhibitor and the decoration contractor are responsible for the strengthening all safety measures and the purchase of suitable insurance policies.
3. In order to maintain the safety of the exhibits, leaseholders shall install security cameras at the exhibition hall, and exhibitors shall take care of their own exhibits and valuable properties. If necessary, exhibitors may install security cameras at their booths. If exhibits or properties are damaged or lost, TAITRA will not be held responsible.
4. If an exhibition hall's facilities are damaged during construction or transportation, the damage shall be repaired or compensation shall be made. If property damage, injury, or death has occurred as a result of a construction accident, the leaseholder shall be held fully responsible for handling the situation and shall bear the relevant legal responsibility.

II. Procedures for handling violations

1. Smoking in exhibition halls is strictly prohibited; penalties for violators are as follows:
 First offence: a warning ticket will be issued without assigning penalty points, and the decoration contractor shall reprimand the employee who smoked



Second offence: a warning ticket and 1 penalty point will be issued

Third offence: a warning ticket with 2 penalty points will be issued

Each subsequent smoking incident will result in additional penalty points. If the violator is an employee of a decoration contractor, once three points have been assigned the decoration contractor, they will lose their eligibility for use of their decoration contractor registration for 1 year, and will be prohibited from entering all TAITRA exhibition halls for construction work.

2. Consumption of alcohol (including alcoholic beverages) and chewing betel nuts or gum inside the exhibition halls is strictly prohibited, and for the purpose of maintaining image and safety, workers are prohibited from being shirtless or wearing slippers while working on site.
3. Unless otherwise specified within these regulations, if leaseholders, exhibitors or decoration contractors violate the regulations stated herein, TAITRA may take the following actions:
 - (1) Cut off water and electricity supply.
 - (2) Close the booth and ban the exhibit.
 - (3) Prohibit the leaseholder, booth contractor, or exhibitor from organizing or participating in an exhibition organized by TAITRA for the next 2 years.
 - (4) One or more of the following punitive actions may be taken, depending on the severity of the violation:
 - i. Each violation can incur a fine between NT\$2,000 to NT\$5,000 (if the payment for the fine is delayed, the fine can be deducted directly from the security deposit, doubling the original amount);
 - ii. In the event of a major accident which was the direct result of violating these regulations, the fine for each incident is NT\$20,000. If violent behavior was used against the exhibition hall's security guards, the fine for the first incident is NT\$10,000, and an additional NT\$10,000 will be added for each repeat offense.
 - iii. Violators who were fined more than twice within one year will be prohibited from entering TAITRA exhibition halls to perform construction work for the next two years.
 - iv. Photos will be taken as proof and all work will be suspended and the violator will also be asked to leave the exhibition hall.
 - v. Those who fail to make improvements in accordance with the regulations set forth by the management unit after being advised to do so will have their booths dismantled by due force. The leaseholder and the decoration contractor are jointly responsible for dismantling fees and failure to cover costs, will let such expenses be deducted from the security deposit directly at double the amount.

21. Customs Regulations for Foreign Exhibits

1. General

- (1) A selection of imported exhibits are allowed to enter Taiwan on a bonded basis without payment of customs duties and may be kept in the bonded warehouse for rent up to three months following the show. Such exhibits should be consigned to "Taiwan External Trade Development Council" (TAITRA).

TAITRA is not in a position to be a consignee for exhibits imported on a duty-paid or deposit basis.

- (2) The following items must be imported on a duty-paid or deposit basis:
 - Non-commercial samples
 - Giveaways or promotional articles
 - Posters, photo panels, catalogues, brochures and leaflets
 - Lubrication oils and greases for maintenance of machinery during the exhibition
 - Materials and equipment for use in the construction, installation, decoration, and maintenance of booths
 - Foodstuffs and drinks to be consumed during the show
 - Jewelry, precious stones, and gold coins (hand carried)
 - Liquors, spirits, wines, and tobaccos
- (3) Exhibits such as fresh flowers, live plants, bulbs, etc. must be imported on a duty-paid basis and in strict observance of "Quarantine Regulations on Importation of Plantation into the Republic of China".



- (4) Note that exhibits such as some telecommunication and military equipment, chemicals, drugs, alcohol, tobacco, fireworks, weapons, and explosives need government endorsement and permits for importation.
- (5) The ATA CARNET is not accepted in Taiwan except in the case of countries having similar bilateral agreements with the Republic of China.

2. Exhibits in Bond

According to customs regulations, goods with bonded status may remain in Taiwan for a maximum of six months from the date of importation. During show-days, exhibits are strictly prohibited from being removed from the premises. Such exhibits should be returned to the bonded warehouse right after the show. They shall neither be sold nor re-exported until all procedures are cleared by the exhibitors concerned. The organizer has the right to return all overdue bonded exhibits on the exhibitor's account without necessarily obtaining the exhibitor's permission.

3. Exhibits Imported on a Deposit or Duty-paid Basis

Exhibits brought in on a deposit or duty-paid basis must be handled by the exhibitor's agent or representative in Taiwan who will act as a consignee and who will be responsible for any and all customs duties.

4. Shipping Mark

All packages to be imported on a bonded basis must be marked as follows:

Show Name: TAITRONICS 2019
Show Dates: October 16 - 18, 2019
Show Site: Taipei Nangang Exhibition Center, Hall 1
Exhibitor: _____
Booth Number: <u>Area:</u> _____ <u>Number:</u> _____
Case Number: _____ of _____
Dimensions: _____
Gross & Net Weight: _____

5. Shipment

- (1) Exhibits on a bonded basis must be shipped on "Freight Prepaid" terms. Sea shipments must be scheduled for arrival at Keelung Port no later than THREE weeks prior to the show opening, and air shipments at Taiwan Taoyuan International Airport no later than TWO weeks, to allow sufficient time for customs clearance. Exhibits arriving at Taichung or Kaohsiung must reach destination ONE week earlier than the above-mentioned schedules. Documents and/or exhibits arriving late will be charged an additional 15% in customs clearance fees and service charges for the extra working hours required to complete procedures.



- (2) For exhibits shipped on a deposit or duty-paid basis, exhibitors may ship them by the forwarders of their choice that have branch offices or agents in Taiwan.
- (3) For bonded exhibits, exhibitors are required to clear customs procedures through one of TAITRA's two official forwarders.

6. Official Forwarders

- (1) Eurotran Expo Service Co., Ltd.
10F., No. 455, Chongyang Rd., Nangang Dist., Taipei, 11560 Taiwan
Tel: 886-2-2785-6000
Fax: 886-2-2785-6701
- (2) Triumph Express Service Co., Ltd.
Room 2A21, 5, Xinyi Road, Section 5, Taipei, Taiwan, 11011 Taiwan
Tel: 886-2-2581-1133
Fax: +886-2-2581-9635

Only the official forwarders will be responsible for handling all exhibits imported on a bonded basis. Their services include customs clearance, transport of exhibits from port of arrival to the exhibition site and vice versa, local storage, unpacking and re-packing, placement of goods in display area, and re-export formalities. The handling charges for all such services will be borne by the exhibitor concerned and calculated according to the tariff listed.

7. Shipping Documentation

- (1) The organizer requires the following documents to clear exhibitor's shipment through Taiwan R.O.C. customs:
 - ◆ 2 Original Ocean Bills of Lading/Airway Bills
 - ◆ 4 Commercial Invoices & Packing Lists
 - ◆ 2 Exhibit Catalogs

The Application Form will be honored only for goods imported on a bonded basis. TAITRA will not accept Commercial Invoice & Packing Lists for goods imported on a duty-paid or deposit basis, since TAITRA is not the consignee.

All above documents along with completed **Application Form** should reach the organizer and official forwarders **FOUR** weeks before the show opens.

Bills of Lading/Airway Bills should be clearly defined with the additional clause "Exhibits are imported for (name of the show) and shall be transferred to TWTC bonded warehouse of Taipei Customs Territory."

- (2) To facilitate the processing of customs clearance procedures, all boxes, crates, etc., should be accompanied by detailed packing lists in duplicate with the identification words of exhibits. Printed materials for the exhibition such as posters, brochures, and leaflets, should not bear any word in Chinese simplified characters.

8. Disposal of Exhibits during & after the Show

- (1) Bonded exhibits:
To provide exhibitors with adequate time to dispose of their exhibits, either by sale locally or by



re-export, the organizer is allowed to store exhibitors' goods in a bonded warehouse for a period of up to three months after the show. Any storage charge incurred will be charged to the account of the exhibitor concerned.

Procedures for the sale of bonded exhibits:

Whether through outright sale or by means of distribution agreement, exhibits can be released from the bonded warehouse only after each and every one of the following procedures has been completed:

a. Securing an import permit:

This is done by the buyer on the basis of the relevant Performa Invoice prepared by the exhibitor.

b. Remittance of cost of goods:

The buyer is responsible for securing the necessary foreign exchange and remitting it to the exhibitor through an authorized bank.

c. Transfer of exhibitor's property to the buyer:

This is accomplished by the exhibitor by completing "Authority/Receipt for Transfer of Exhibitor's Property", which must be signed by the exhibitor and countersigned by Taiwan External Trade Development Council.

d. Payment of import duties:

This is also the responsibility of the buyer.

(2) Duty-paid or deposit basis:

Goods can be released from the showground only after the show closes, regardless when the said goods are sold.

(3) Re-exportation of exhibits:

Exhibitors shall instruct the official forwarders concerned to take the necessary steps as soon as re-exportation of exhibits is decided.

22. Personal Information Protection

The personal information in TAITRONICS application forms will only be used for personal contact by phone, mail and other means of communication in the years 2019-2021. Those who wish to exercise any of the following rights, please contact TAITRONICS and AIoT TAIWAN 2019 organizer:

1. Make inquiry and request for a review of personal information;
2. Make request for duplications of personal information;
3. Request to supplement or correct personal information;
4. Request to end collection, processing or use of personal information; and
5. Request deletion of personal information

*** This English-language abridged version of the TAITRONICS AND AIOT TAIWAN 2019 Exhibitors Manual is for reference purpose only, and the Chinese edition will prevail if there is any discrepancy between the two.**



23. Tariff for Heavy Duty Electric Power

Item	Description of Service	Unit Cost (NT\$)
1	AC 110V 60 Cycle single phase 5A (500W)	625
2	AC 110V 60 Cycle single phase 10A (1000W)	1,250
3	AC 110V 60 Cycle single phase 15A (1500W)	1,875
4	AC 110V 60 Cycle 2KW	2,500
5	AC 110V 60 Cycle 4KW	5,000
6	AC 110V 60 Cycle 6KW	7,500
7	AC 110V 60 Cycle 9KW	11,250
8	AC 110V 60 Cycle 12KW	15,000
9	AC 110V 60 Cycle 15KW	18,750
10	AC 110V 60 Cycle 18KW	22,500
11	AC 110V 60 Cycle 22KW	27,500
12	AC 220V 60 Cycle 15A	2,920
13	AC 220V 60 Cycle 20A	5,521
14	AC 220V 60 Cycle 30A	7,571
15	AC 220V 60 Cycle 40A	9,864
16	AC 220V 60 Cycle 50A	11,890
17	AC 220V 60 Cycle 60A	15,638
18	AC 220V 60 Cycle 75A	17,953
19	AC 380V 60 Cycle 15A	7,227
20	AC 380V 60 Cycle 20A	9,032
21	AC 380V 60 Cycle 30A	12,170
22	AC 380V 60 Cycle 40A	14,836
23	AC 380V 60 Cycle 50A	17,501
24	AC 380V 60 Cycle 60A	22,372
25	AC 440V 60 Cycle 15A	7,858
26	AC 440V 60 Cycle 20A	9,874
27	AC 440V 60 Cycle 30A	13,433
28	AC 440V 60 Cycle 40A	16,519
29	24hrs AC 110V 60 Cycle single phase 5A	1,901
30	24hrs AC 110V 60 Cycle single phase 15A	2,711
31	24hrs AC 110V 60 Cycle single phase 20A	3,116
32	24hrs AC 220V 60 Cycle 3 phase 15A	8,759
33	24hrs AC 220V 60 Cycle 3 phase 20A	13,575
34	24hrs AC 220V 60 Cycle 3 phase 30A	17,607
35	Water/Drainage installation	2,363
36	Compressed Air	5,000

Remarks:

1. The exhibitors shall be fully responsible for any claim of damage to property or injury to any person arising out of improper installation of electric facilities in his booth.
2. No application shall be accepted on or after the first day of move-in.
3. Any cancellation must be made in writing 10 days prior to the opening for the show, after which 80% of duly paid charges will be re-funded. No refund will be made if a request for cancellation is overdue.
4. Deadline: **September 11, 2019**



24. Estimated Power Consumption for Electrical Appliances

Item	Power Consumption
Square Spotlight	300W
Round Spotlight	100W
Halogens Light	50W
Florescent Lamp	10~40W
Personal Computer	100~200W
Notebook	20~50W
Monitor	50~100W
Laser Printer	500~800W
Jet Printer	30~150W
Point Printer	100~200W
Computer Graphic Machine	50~500W
Television	150W
Video Set	50W
Audio Set	100~200W
Refrigerator	80~200W
Drinking Water Machine	600W
Hot Plate	800W
Microwave Oven	800W
Coffee Maker	600W
Photo Copier	1,000~1,500W
Fax Machine	100W
Electric Fan	100W
Overhead Projector	800W
Slide Projector	600W

Remarks:

1. The above estimates are for reference only.
2. 1KW = 1,000W
3. Each booth is entitled to the free use of 500 Watts of 110V electricity

Power Fee	Payment (Discount/Surcharge)
Before August 20	20% Discount Charge
August 21 – September 11	Set Price
September 12 – 26	20% Overdue Charge
After September 27	50% Overdue Charge



25. Electricity & Water / Drainage Requirements

Each booth is supplied with 110 volts 0.5 KW power free of charge. Exhibitors requiring additional or heavy-duty power supply should apply for such requirements by completing the following:

DESCRIPTION OF SERVICE	QTY
AC 110V 60 Cycle single phase 5A (0.5 KW)	
AC 110V 60 Cycle single phase 15A(1.5 KW)	
AC 110V 60 Cycle single phase 20A(2 KW)	
AC 110V 60 Cycle 4 KW	
AC 110V 60 Cycle 6 KW	
AC 110V 60 Cycle 9 KW	
AC 110V 60 Cycle 15 KW	
AC 110V 60 Cycle 22 KW	
AC <input type="checkbox"/> 220V <input type="checkbox"/> 380V <input type="checkbox"/> 440V 60 Cycle 3 phase 15A	
AC <input type="checkbox"/> 220V <input type="checkbox"/> 380V <input type="checkbox"/> 440V 60 Cycle 3 phase 20A	
AC <input type="checkbox"/> 220V <input type="checkbox"/> 380V <input type="checkbox"/> 440V 60 Cycle 3 phase 30A	
AC <input type="checkbox"/> 220V <input type="checkbox"/> 380V <input type="checkbox"/> 440V 60 Cycle 3 phase 40A	
AC <input type="checkbox"/> 220V <input type="checkbox"/> 380V 60 Cycle 3 phase 50A	
AC <input type="checkbox"/> 220V <input type="checkbox"/> 380V 60 Cycle 3 phase 60A	
AC <input type="checkbox"/> 220V 60 Cycle 3 phase 75A	
24hrs AC 110V 60 Cycle single phase 5A	
24hrs AC 110V 60 Cycle single phase 15A	
24hrs AC 110V 60 Cycle single phase 20A	
24hrs AC 220V 60 Cycle 3 phase 15A	
24hrs AC 220V 60 Cycle 3 phase 20A	
24hrs AC 220V 60 Cycle 3 phase 30A	
Water/Drainage installation	
Compressed Air	

Remarks:

- Electricity will be provided on the day before the show from 8 a.m. to 6 p.m.
- Electricity will be provided during show hours.
 Oct. 16, 2019 9 a.m. to 6:30 p.m.
 Oct. 17, 2019 9:30 a.m. to 6:30 p.m.
 Oct. 18, 2019 9:30 a.m. to 5:30 p.m.
- To ensure electrical safety of exhibits, exhibitors should install Active Voltage Regulation/Regulator (AVR) or Uninterruptible Power Supply (UPS).
- The exhibitors shall be fully responsible for any claim of damage to property or injury to any person arising out of improper installation of electric facilities in his booth.
- No application shall be accepted on or after the first day of move-in.
- Any cancellation must be made in writing 10 days prior to the opening for the show, after which 80% of duly paid charges will be re-funded. No refund will be made if a request for cancellation is overdue.
- The electrical wiring diagram should be submitted by your contractor in Chinese edition.

Company: _____ Booth No.: _____

Contact person: _____ E-mail: _____

Mobile Phone: _____ Tel: _____ Fax: _____



26. Booth Construction Assurance

As a participant in the TAITRONICS 2019 being held at Taipei Nangang Exhibition Center, Hall 1 from October 16 to 18, 2019, we ensure:

That the booth(s) is constructed in compliance with Taipei Nangang Exhibition Center, Hall 1 Decoration Guidelines, and

That our contractor will clear all materials from our booth space and remove such to the approved place before the end of the move-out date, and

If the booth and all materials are not removed, we will assume responsibility for all compensation and civil liability, and also agree that the show management has the right to remove all such materials.

※Please email to brianwen@taitra.org.tw before September 20 and bring this form with business card to Exhibitor's Registration counter to collect the exhibitor's badges upon arrival at the exhibition hall during exhibitor's move-in hours.

Exhibitor: _____

Booth Number: Area _____ Number: _____

President of the company: _____ (Sign and Print)

Contact Person: _____ (Sign and Print)

Mobile Phone: _____ Tel: _____

Email: _____

Booth Contractor: _____

Contact person: _____

Mobile Phone: _____ Tel: _____

Email: _____

Address: _____

Date: _____

The above personal information will only be used for personal contact by phone, mail and other means of communication in the years 2019-2022.

Those who wish to exercise any of the following rights, please contact TAITRONICS/AIoT Taiwan 2019 organizer:

1.Make inquiry and request for a review of personal information; 2.Make request for duplications of personal information; 3.Request to supplement or correct personal information; 4.Request to end collection, processing or use of personal information; and 5.Request deletion of personal information



27. Safety and Health Terms of Agreement

Taiwan External Trade Development Council Safety and Health Terms of Agreement for Exhibitors

After attending TAITRONICS 2019 space allocation meeting as well as workers safety meeting, the undersigned parties have fully understood workers safety and health regulations required by the Taiwan External Trade Development Council (TAITRA). The undersigned parties and any other affiliated parties will duly comply with governmental Occupational Safety and Health Act and related regulations and TAITRA guidelines. In the event of any work-related incidents and/or accidents, the undersigned parties, along with any other affiliated parties, shall be solely responsible for any legal and/or compensational proceedings pertaining thereto. The undersigned parties, along with any other affiliated parties, shall not damage equipment or machinery belonging to or leased from TAITRA, and are fully responsible for all compensation or repairs in the event of damage.

The undersigned parties and any other affiliated parties guarantee to comply with the following regulations during the operational period :

1. **The Standard Pre-Construction Procedures of TAITRA**
2. **The Worker Safety and Health Management Procedures of TAITRA**
3. **On-Site Hazards Notification**

To enforce regulations set by the Labor Standards Inspection Office of the Taipei City Government, exhibition hall staff will photograph and impose fines for breaches of safety, including (but not limited to) lack of required entry and work permits, lack of any required uniforms, lack of safety helmets, unfastened safety belts at heights of 1.5 meters or above, lack of monitoring and controlling personnel on site during the use of tower cranes or forklifts, and lack of safety cones and personnel restrictions under suspended objects. TAITRA has the right to refuse entry to construction workers or companies under hire by exhibition participants who fail to comply with the above rules. Please complete this form and email to brianwen@taitra.org.tw before September 20. Exhibitors will need to bring this form with business card to Exhibitor's Registration counter to collect the exhibitor's badges upon arrival at the exhibition hall during exhibitor's move-in hours.

The exhibitor is fully aware of the contents of above-mentioned regulations as well as management regulations of TAITRA.

Exhibitor: _____

Booth Number: Area _____ Number: _____

President of the company: _____ (Sign and Print)

Contact Person: _____ (Sign and Print)

Mobile Phone: _____ Tel: _____

Email: _____

Date: _____

The above personal information will only be used for personal contact by phone, mail and other means of communication in the years 2019-2022.

Those who wish to exercise any of the following rights, please contact TAITRONICS/AIoT Taiwan 2019 organizer:

1. Make inquiry and request for a review of personal information;
2. Make request for duplications of personal information;
3. Request to supplement or correct personal information;
4. Request to end collection, processing or use of personal information; and
5. Request deletion of personal information.



28. Dimensions of Meeting Rooms at Taipei Nangang Exhibition Center, Hall 1

Meeting Room	Capacity					Area (sqm/ping)	Dimensions LxWxH (M)	Cost per session (NT\$) Session #1: 08:00-12:00 Session #2: 13:00-17:00 Session #3: 18:00-22:00
	Theater	Classroom	Standard	U shape	Square			
401	384	144	216	52	72	375.7/113.7	20.2x18.6x3.5	41,800
402	396	168	224	62	80	372.6/112.7	27.0x13.8x3.5	41,100
402a	100	56	72	26	36	121.4/36.7	8.8x13.8x3.5	13,500
402b	110	56	72	26	36	122.8/37.1	8.9x13.8x3.5	13,400
402c	110	56	72	26	36	128.3/38.8	9.3x13.8x3.5	14,200
402a+b	234	108	144	42	56	244.3/73.9	17.7x13.8x3.5	26,900
402b+c	234	108	144	42	56	251.2/76	18.2x13.8x3.5	27,600
403	125	68	92	34	44	149.5/45.2	8.4x17.8x3.5	16,300
404	90	48	72	26	36	133.5/40.4	9.3x12.9x3.5	14,600
501	105	56	84	30	36	131.1/39.7	9.3x14.1x2.8	14,400
502	95	34	68	26	32	102.3/30.9	7.6x12.0x2.8	11,100
503	110	56	84	30	36	150.9/45.7	9.7x14.2x2.6	16,300
504	504	224	360	68	84	505.4/152.9	26.6x19x2.8	54,900
504a	165	80	120	38	44	184.3/55.8	9.7x19x2.8	20,100
504b	150	80	120	38	44	169.1/51.2	8.9x19x2.8	18,400
504c	150	80	120	38	44	152/46	8.0x19x2.8	16,400
504a+b	336	144	216	48	64	353.4/106.9	18.6x19x2.8	38,500
504b+c	312	128	216	48	64	321/97.1	16.9x19x2.8	34,800
505	140	72	116	46	52	159.8/48.3	9.7x18.6x2.8	17,400
609	132	64	56	34	40	128/38.71	14.21x9.8x3	13,900
614	140	72	80	46	52	149.2/45.12	17.8x7.9x3	16,200
616	140	72	80	42	48	166.5/50.4	16.9x9.8x3	18,100
631	117	54	108	42	52	159.93/48.38	17.9x9.42x3	17,400



Additional Information

- * Application is for TAITRONICS exhibitors only.
- * Applications for meeting rooms are accepted on a first-come, first-served basis.
- * Food, beverage, and audio-visual equipment cannot be brought into the meeting rooms.
- * Prior approval is needed if Food & Beverage will be served inside conference rooms. The following guidelines must be followed :
 - (1) Meeting refreshments can only be provided by official contactors of Taipei Nangang Exhibition Center, Hall 1.
 - (2) Tables for Coffee & Tea have to be set up on the hallway adjacent to the conference room rented.
 - (3) Tables cloth (offered by Taipei Nangang Exhibition Center, Hall 1) must be used for Dining. A clean-up fee (extra 5% of the 4-hour rental) will be charged along with the lease fee.
 - (4) Additional carpets are required if banquets will be held inside conference rooms. A clean-up fee (extra 5% of the 4-hour rental) will be charged along with the lease fee.
- * Those using premises overtime will be charged a full 4-hour rental.
- * Meeting rooms must be restored to their original condition after use. The operators may ask for compensation for damages to equipment caused by the occupants.

- * For meeting room booking in Taipei Nangang Exhibition Center, Hall 1, please contact:
Mr. Cavan Pai, TAITRA
Tel: 886-2-2725-5200 Ext. 2874
Email: cavan@taitra.org.tw



TAITRONICS 2019 Meeting Room Booking Form

Date : _____

Company Name : _____

Invoice No. : _____ Booth No. : _____

Address : _____

Contact Person : _____ Phone : _____

E-mail : _____ Fax : _____

No.	Meeting Room No.	Session	Price (NT\$)
1			
2			
3			
4			
5			
Subtotal			
5%VAT			
Total			

Company Stamp : _____

Legally Binding Signature : _____

Remarks :

1. Applications are accepted on a first-come, first-served basis.
2. Maximum of 3 meeting room hire/per exhibitor.
3. For Meeting Room Package booking, please E-MAIL the completed application form to :

Mr. Cavan Pai, TAITRA

Tel: 886-2-2725-5200 Ext. 2874

Email: cavan@taitra.org.tw

2019

TAIWAN International Trade Shows

Official Contractor | Interplan International Corp.



NOTE

- The official contractors of Taiwan Trade show in 2019 are both Interplan Group-Interplan International Corporation and OLILY Group – OYA Marketing Solution and Interior Design Co., Ltd.
- Exhibitors who have signed up for “Raw Space” booths (such space has NO equipment, water or power outlets), should contact one of the official contractors or arrange with other decoration contractors for set-up.
- Exhibitors, who have signed up for the Organizer-provided “Booth with shell scheme” and who require additional equipment, such as furniture or extra electricity, must rent the equipment from the designated exhibition contractor who sets up the “Booth with shell scheme” . For further details about each show’s designated decoration contractor see Exhibition Manual of the relevant exhibition.
- Exhibitors shall pay due attention to the price and the deadline of each invoice and make payment on time and shall also read through all regulations and clarify any questions with the contractor so as to avoid any dispute.
- For information regarding terms and regulations related to decoration and construction of booths, please refer to the Exhibitor Manual: REGULATIONS GOVERNING BOOTH DECORATION WITHIN THE TAIPEI WORLD TRADE CENTER EXHIBITION HALL.

interplan

Interplan International Corporation

Interplan group is one of the outstanding agencies in the Asia Pacific region, which has been a leading brand in Taiwan's M.I.C.E. industry. With increasing demand for integrated services, we successfully expanded and diversified our business scope. Interplan services range from event organizing, content and design creation to production as well as trade show & venue management. We strive to serve the interests of our clients, to upkeep and continually establish new benchmarks ensuring the success of every event.



Exhibition Planning • Space Design • Signage • Shop Fitting • Museum • Concept Stores • Multimedia Effect • Brand Communication • Convention • Event • Road shows • Corporate Image Building

A. Shell Scheme Booth



Booth Type : 1-1

Square measure : 300x300x250CM/H

Including :

1. Needle punch carpet (light grey) 9SQM
2. Company name fascia board
(white board with blue letters) 1set
3. 10W LED Spotlight (Yellow light) 3pcs
4. Meeting Table Dia 60x75CM/H 1pc
5. Folding Chair 3pcs
6. Trash can 1pc

UNIT PRICE : US\$156 (VAT excluded)



Booth Type : 2-1

Square measure : 600x300x250CM/H

Including :

1. Needle punch carpet (light grey) 18SQM
2. Company name fascia board
(white board with blue letters) 2sets
3. 10W LED Spotlight (Yellow light) 6pcs
4. Info Counter 100x50x82.5CM/H 1pc
5. Meeting Table Dia 60x75CM/H 1pc
6. Folding Chair 6pcs
7. Trash can 1pc

UNIT PRICE : US\$311 (VAT excluded)

Selecting color for your Company name fascia board



Notice

1. Exhibitors who do not use any of the standard equipment shall consider it waived and furniture replacement will not be accepted.
2. Additional furniture rental will require both the application form (page 17-20) and a booth layout being submitted.
3. Nothing may be stuck, screwed, or nailed to the stand. Nor may it be painted, modified or damaged. You may mount posters using Powerstrips® or similar material, which does not leave any sticky residue upon removal.

B. Design Package Booth



Booth Type : 1-2

Square measure : 300x300x250/400CM/H

Including :

1. Needle punch carpet (light grey) 9SQM
2. Special design System Tower (300CM/H)
3. companyname 0.3cm thickness 1pc
4. 10W LED spotlight (Yellow light) 3pcs
5. 52W LED arm spotlight (Yellow light) 2pcs
6. Info Counter 100x50x82.5CM/H 1pc
7. System Showcase (50x50x400CM/H) 1pc
8. Folding Chair 2pcs
9. Trash can 1pc

UNITPRICE : US\$555 (VAT excluded)



Booth Type : 1-3

Square measure : 300x300x250/350CM/H

Including :

1. Needle punch carpet (light grey) 9SQM
2. Special design System Tower (300CM/H)
3. companyname 0.3cm thickness 1pc
4. 10W LED spotlight (Yellow light) 3pcs
5. 52W LED arm spotlight (Yellow light) 2pcs
6. Info Counter 100x50x82.5CM/H 1pc
7. Meeting Table Dia 60x75CM/H 1pc
8. Folding Chair 3pcs
9. Trash can 1pc

UNITPRICE : US\$575 (VAT excluded)

Note : 1. Additional furniture rental please fill in Additional Order Form (P.17-20). 2. Nothing may be stuck, screwed, or nailed to the stand. Nor may it be painted, modified or damaged. 3. Any other requirements please contact us. e-mail: twtc@interplan.com.tw

B. Design Package Booth



Booth Type : 1-4

Square measure : 300x300x350CM/H

Including :

1. Needle punch carpet (light grey) 9SQM
2. PVC cutting company logo and name 2pcs
3. 10W LED spotlight (Yellow light) 3pcs
4. 52W LED arm spotlight (Yellow light) 2pcs
5. Info Counter 100x50x82.5CM/H 1pc
6. Meeting Table Dia 60x75CM/H 1pc
7. Folding Chair 4pcs
8. Trash can 1pc

UNIT PRICE : US\$410 (VAT excluded)



Booth Type : 1-5

Square measure : 300x300x400CM/H

Including (poster excluded) :

1. Needle punch carpet (light grey) 9SQM
2. Tower PVC cutting company logo 1pc
3. PVC cutting company name 1pc
4. 10W LED spotlight (Yellow light) 3pcs
5. 52W LED arm spotlight (Yellow light) 2pcs
6. Info Counter 100x50x82.5CM/H 1pc
7. System Showcase (100x50x200CM/H) 1pc
8. Meeting Table Dia 60x75CM/H 1pc
9. Folding Chair 4pcs
10. Trash can 1pc

UNIT PRICE : US\$535 (VAT excluded)

Note : 1. Additional furniture rental please fill in Additional Order Form (P.17-20). 2. Nothing may be stuck, screwed, or nailed to the stand. Nor may it be painted, modified or damaged. 3. Any other requirements please contact us.
e-mail: twtc@interplan.com.tw

B. Design Package Booth



Booth Type : 1-6

Square measure : 300x300x350CM/H

Including :

1. Needle punch carpet (light grey) 9SQM
2. LED Light box with PVC companyname 2sets
3. System fascia board 200x100CM/H 1set
4. 10W LED spotlight (Yellow light) 3pcs
5. 52W LED arm spotlight (Yellow light) 2pcs
6. Info Counter 100x50x82.5CM/H 1pc
7. Meeting Table Dia 60x75CM/H 1pc
8. Folding Chair 4pcs
9. Trash can 1pc

UNITPRICE : US\$555 (VAT excluded)



Booth Type : 1-7

Square measure : 300x300x350CM/H

Including (poster excluded) :

1. Needle punch carpet (light grey) 9SQM
2. Tower companyname 3cm thickness 1pc
3. PVC cutting company website 1pc
4. 10W LED spotlight (Yellow light) 3pcs
5. 52W LED arm spotlight (Yellow light) 2pcs
6. Info Counter 100x50x82.5CM/H 1pc
7. Meeting Table Dia 60x75CM/H 1pc
8. Folding Chair 4pcs
9. Trash can 1pc

UNITPRICE : US\$645 (VAT excluded)

Note : 1. Additional furniture rental please fill in Additional Order Form (P.17-20). 2. Nothing may be stuck, screwed, or nailed to the stand. Nor may it be painted, modified or damaged. 3. Any other requirements please contact us. e-mail: twc@interplan.com.tw

B. Design Package Booth



Booth Type : 1-8

Square measure : 300x300x350CM/H

Including :

1. Needle punch carpet (light grey) × 9SQM
2. PVC cutting companyname 1pc
3. Round 1/4 showcase 50x50x350CM/H 1pc
4. System light box 100X30X150CM/H 1pc
5. Info counter 100x50x82.5CM/H 1pc
6. Meeting Table Dia 60x75CM/H 1pc
7. Folding Chair 4pcs
8. 10W LED spotlight (Yellow light) 3 pcs
9. 52W LED Arm spotlight (Yellow light) 2pcs
10. Trash can 1pc

UNITPRICE : US\$610 (VAT excluded)



Booth Type : 1-9

Square measure : 300x300x350CM/H

Including : (poster excluded)

1. Needle punch carpet (light grey) 9SQM
2. Light box with PVC companyname 1set
3. Companyname fascia board 150x50cm/H 1pc
4. 10W LED spotlight (Yellow light) 5pcs
5. Info Counter 100x50x82.5CM/H 1pc
6. Meeting Table Dia 60x75CM/H 1pc
7. Folding Chair 4pcs
8. Trash can 1pc

UNITPRICE : US\$645 (VAT excluded)

Note : 1. Additional furniture rental please fill in Additional Order Form (P.17-20). 2. Nothing may be stuck, screwed, or nailed to the stand. Nor may it be painted, modified or damaged. 3. Any other requirements please contact us. e-mail: twc@interplan.com.tw

B. Design Package Booth



Booth Type : 2-2

Square measure :

600x300x400CM/H

Including :

1. Needle punch carpet (light grey) 18SQM
2. PVC cutting company name & logo 4pcs
3. 10W LED Spotlight(Yellow light) 8pcs
4. 52W LED armpointlight(Yellow light) 2pcs
5. Info Counter100x50x82.5CM/H 1pc
6. Meeting Table Dia 60x75CM/H 1pc
7. Folding Chair 4pcs
8. Plant (S) 2pcs
9. Trash can 1pc

UNITPRICE : US\$875

(VAT excluded)



Booth Type : 2-3

Square measure :

600x300x350CM/H

Including :

1. Needle punch carpet(light grey) 18SQM
2. Tower company name
3cm thickness, H=50CM 1set
3. PVC cutting company website 1pc
4. PVC cutting company logo
150x100cm/H 1set
5. 52W LED armpointlight(Yellow light) 2pcs
6. 10W LED spotlight (Yellow light) 6pcs
7. Ceiling downlight× 2pcs
8. Info Counter100x50x82.5CM/H 1pc
9. Meeting Table Dia 60x75CM/H × 1pc
10. Folding Chair× 4pcs
11. Trash can× 1pc

UNITPRICE : US\$1,197

(With TV) : US\$1,450

(VAT excluded)

Note : 1. Additional furniture rental please fill in Additional Order Form (P.17-20). 2. Nothing may be stuck, screwed, or nailed to the stand. Nor may it be painted, modified or damaged. 3. Any other requirements please contact us. e-mail: twtc@interplan.com.tw

B. Design Package Booth



Booth Type : 2-4
Square measure :
600x300x400CM/H

Including :

1. Needle punch carpet (light grey) 18SQM
2. Companyname 0.5cm thickness 1pc
3. Fascia board 250x100CM/H 2pcs
4. PVC cutting company website 1pc
5. 52W LED arm spotlight (Yellow light) 6pcs
6. 10W LED spotlight (Yellow light) 6pcs
7. Info Counter 100x50x82.5CM/H 2pcs
8. Meeting Table Dia 60x75CM/H 1pc
9. Folding Chair 4pcs
10. Trash can 1pc

UNIT PRICE : US\$1,160
(VAT excluded)



Booth Type : 2-5
Square measure :
600x300x400CM/H

Including : (poster excluded)

1. Needle punch carpet (light grey) 18SQM
2. Styrofoam company name 3cm thickness, H=40CM 1set
3. 52W LED arm spotlight 3pcs
4. 10W LED downlight 4pcs
5. Info Counter 100x50x82.5CM/H 1pc
6. Meeting Table Dia 60x75CM/H 1pc
7. Folding Chair 4pcs
8. Trash can 1pc

UNIT PRICE : US\$1,285
(VAT excluded)

Note : 1. Additional furniture rental please fill in Additional Order Form (P.17-20). 2. Nothing may be stuck, screwed, or nailed to the stand. Nor may it be painted, modified or damaged. 3. Any other requirements please contact us. e-mail: twtc@interplan.com.tw

B. Design Package Booth



Booth Type : 2-6

Square measure :

600x300x400CM/H

Including :

1. Needle punch carpet (light grey) 18SQM
2. PP Plate Shet 600X100CM/H 1pc Fascia board PVC 300x80CM/H 1pc
3. 10W LED spotlight (Yellow light) 6pcs
4. 10W LED downlight (Yellow light) 5pcs
5. Lumina Counter 200x50x110CM/H 1pc
6. Meeting Table Dia 60x75CM/H 1pc
7. Folding Chair 6pcs
8. Trash can 1pc

UNITPRICE : US\$1,035

(VAT excluded)



Booth Type : 2-7

Square measure :

600x300x400CM/H

Including :

1. Needle punch carpet (light grey) 18SQM
2. Styrofoam company name 3cm thickness, H=40CM 1set
3. PVC cutting company website 1pc
4. 10W LED spotlight (Yellow light) 6pcs
5. 52W LED arm spotlight 2pcs
6. Info Counter 100x50x82.5CM/H 1pc
7. Meeting Table Dia 60x75CM/H 1pc
8. Folding Chair 6pcs
9. Trash can 1pc

UNITPRICE : US\$1,145

(VAT excluded)

Note : 1. Additional furniture rental please fill in Additional Order Form (P.17-20). 2. Nothing may be stuck, screwed, or nailed to the stand. Nor may it be painted, modified or damaged. 3. Any other requirements please contact us. e-mail: twtc@interplan.com.tw

C. Additional Equipment



3.1 / 3.2
接待桌
Information counter
100x50x82.5/100 cm/H



3.3
弧形系統接待桌
Curve Information counter
153x50x82.5/100 cm/H



3.4 / 3.5
儲物櫃
Cupboard w/ lock
100x50x82.5/100 cm/H



3.6 / 3.7
長方形展台
Display box
100x50x82.5/100 cm/H



3.8
方形展台
Square display box
50x50x82.5/100 cm/H



3.9 / 3.10
1/4圓系統展台 1/4
round display box
50x70x82.5/100 cm/H



3.11
階梯形系統展台
Two-tier display box
100x100x50/100 cm/H



3.12
玻璃矮櫃 Table
showcase
100x50x100 cm/H



3.13
玻璃高櫃 (附鎖、嵌燈*2、玻璃層板*1)
Tall showcase(w/ lock、嵌燈*2、玻璃層板*1)
100x50x200 cm/H

注意事項 :1. 租用設備請填寫增租配備表 (P.17-20) 。 2. 上述設備照片僅供參考。

如有其他設備租用需求，請電洽：(02)2722 7777 /e-mail: twc@interplan.com.tw

C. Additional Equipment



3.15 / 3.16 / 3.17
層板(平、斜、玻璃)
Wooden shelf (flat、slope), Glass shelf (flat)
100x30 cm

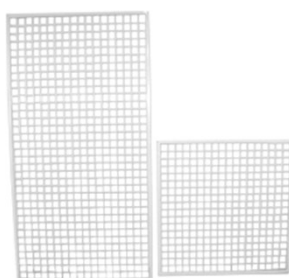

3.18 / 3.19
鐵網
Grid/Wire mesh
(大/L)90x180 cm(小/S)90x90 cm



3.20 / 3.21
洞洞板
Pegboard
(大/L) 90x180 cm(小/S)90x90cm

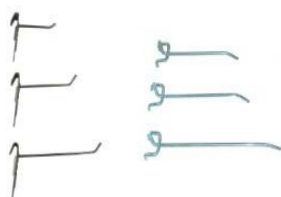

3.22 / 3.23 / 3.24
鐵網、洞洞板掛勾
Hook
5/10/15 cm



3.28
系統掛衣架
Coat rack



3.25
白色系統隔間板
System partition
100x250cm/H



3.26 / 3.27
系統木門 / 折門
Wooden door / Folding door
100x200cm/H



注意事項 :1. 租用設備請填寫增租配備表 (P.17-20) 。 2. 上述設備照片僅供參考。

如有其他設備租用需求，請電洽：(02)2722 7777 /e-mail: twc@interplan.com.tw

C. Additional Equipment



3.29
木製高櫃 附高飽和LED燈8個 (含110V/5A插座*1) Tall
showcase (lock down/LED x8, including socket x1)
100X50X190cm/H



3.30
木製低櫃附高飽和LED燈2個T5-1個 (含110V/5A插座*1) Table
showcase (lock down/LED x2 /T5x1, including socket x1)
100X50X105cm/H



3.31
立櫃附LED燈5個 (含110V/5A插座*1) Tall
showcase (LED x5 ,including socket x1)
50X50X190cm/H

顏色選項參考：



白色 / White 米色 / Ivory 黑色 / Black B組 D組

(數量有限 · 訂完為止/ Limited Quantity)



沙發 /Sofa
89X87X76cm/H (黑 / Black)
69X70X77cm/H (白 /White)



小茶几 /coffe table
55X55X45cm/H

注意事項 :1. 租用設備請填寫增租配備表 (P.17-20) 。 2. 上述設備照片僅供參考。

如有其他設備租用需求 · 請電洽 : (02)2722 7777 /e-mail: twc@interplan.com.tw

C. Additional Equipment



3.32
造型吧台椅
Bar stool
45x45x70cm/H



3.33
方塊椅
Squire
40x40x40 cm/H



3.34 /3.35
靠背吧台椅&高腳圓桌
stool & Bar table Dia
60x110cm/H



3.36 /3.37
圓桌&折椅
Meeting table & Folding chair



3.38
軟墊扶手椅(白、黑、紅、藍)
Labofa chair
48x48x45cm/H

注意事項 :1. 租用設備請填寫增租配備表 (P.17-20) 。 2. 上述設備照片僅供參考。

如有其他設備租用需求，請電洽：(02)2722 7777 /e-mail: twc@interplan.com.tw

C. Additional Equipment



4.1 /4.2 /4.3 /4.4
10W LED (長柄) 投光燈
10W LED (Arm) Spotlight



4.5 /4.6 /4.7 /4.8
52W LED (長柄) 投光燈
52W LED (Arm) Spotlight



4.9 / 4.10
10W LED 投光燈/長臂投光燈(聚光)
10W (Arm) LED Spotlight



4.11
50W 櫃內立燈
50W Interior lamp



4.12 /4.13
110V/5A插座 220V/5A插座
110V/5A 220V/5A Socket



4.16
飲水機(附水X3)
Water dispenser with waterX3



4.19
42"LED電視
42" Plasma



4.21
小冰箱/Refrigerator
47X49X79cm/H



咖啡機
Coffee machine

注意事項 :1. 租用設備請填寫增租配備表 (P.17-20) 。 2. 上述設備照片僅供參考。

如有其他設備租用需求，請電洽：(02)2722 7777 /e-mail: twc@interplan.com.tw

C. Additional Equipment



X展架 60x160cm/H
易拉展 90 /120 x200cm/H
Retractable Roll Up Banner Stand

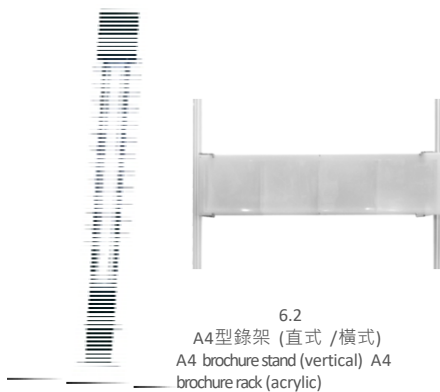

6.2
A4型錄架 (直式 / 橫式)
A4 brochure stand (vertical) A4
brochure rack (acrylic)



6.3 / 6.4
盆景 (大、中、小)
Plant (L、M、S)



壓克力桌牌(A4,A5大小)
Acrylic desk plate
210*297cm, 210*149cm



海報架 Poster stand (小
) (S) 60x45cm, H=145cm Poster size: 49*41cm/H (大
) (L) 85x65cm, H=168cm Poster size: 73*60cm/H



伸縮銅柱 Extendable railing
H=100cm, L=200cm

注意事項 : 1. 租用設備請填寫增租配備表 (P.17-20) 。 2. 上述設備照片僅供參考。

如有其他設備租用需求，請電洽 : (02)2722 7777 / e-mail: twc@interplan.com.tw

D. Additional Order Form 1

FAIR :

BOOTH NO. :

COMPANY NAME :

CONTACT NAME :

E-MAIL ADDRESS :

PHONE NO. :

BOOTH TYPE 9SQM (3Mx3M)					BOOTH TYPE 18SQM (6Mx3M)				
ITEM	NO.	UNITPRICE (US \$)	QTY	PRICE	ITEM	NO.	UNITPRICE (US \$)	QTY	PRICE
Shell Scheme Booth	1-1	156			Schell Scheme Booth	2-1	311		
Design Package Booth	1-2	555			Design Package Booth	2-2	875		
	1-3	575				2-3	1,197		
	1-4	410				2-3(TV)	1,450		
	1-5	535				2-4	1,160		
	1-6	555				2-5	1,285		
	1-7	645				2-6	1,035		
	1-8	610				2-7	1,145		
	1-9	645							

SYSTEM FURNITURE					
NO.	ITEM		UNIT PRICE(US \$)	QTY	PRICE
3.1	Info Counter 100X50X82.5cm/H	Pc	18		
3.2	Info Counter 100X50X100cm/H	Pc	32		
3.3	Curved Info Counter (single seat only) 153X50X82.5cm/H	Pc	54		
3.4	Cupboard (including lock) 100X50X82.5cm/H	Pc	21		
3.5	Cupboard (including lock) 100X50X100cm/H	Pc	29		
3.6	Display Counter 100X50X82.5cm/H	Pc	18		
3.7	Display Counter 100X50X100cm/H	Pc	25		
3.8	Display Counter 50X50X82.5cm/H	Pc	11		
3.9	1/4 Round Display Counter 50X70X82.5cm/H	Pc	18		
3.10	1/4 Round Display Counter 50X70X100cm/H	Pc	21		
3.11	Two-tier Display Counter 100X50X50/100cm/H	Pc	54		
3.12	Table Showcase 100x50x100cm/H, including lock	Pc	70		
3.13	Tall Showcase 100x50x200cm/H including lock,shelfx1 and 2 pieces of Down Light 50W	Pc	143		
3.14	Tall Showcase 50x50x200cm/H including lock,shelfx1 and 2 pieces of Down Light 50W	Pc	108		
3.15	Flat Wooden Shelf 100X30cm	Pc	11		
3.16	Slope Wooden Shelf 100X30cm	Pc	11		
3.17	Flat Glass Shelf 100X30cm	Pc	15		
3.18	Grid/ Wire Mesh (S)(exclude hook) 90X90cm/H	Pc	21		
3.19	Grid/ Wire Mesh (L)(exclude hook) 90X180cm/H	Pc	32		
3.20	Pegboard (S)(exclude hook) 90X90cm/H	Pc	29		

Note : 1. A 30% surcharge will occur for orders received after the deadline (30 days prior to fair opening) and 50% surcharge will apply with onsite orders. 2. Order won't be completed without Form P.17-20. 3. Other Service please contact us.
e-mail: twtc@interplan.com.tw

D. Additional Order Form 2

FAIR : **BOOTH NO. :** **COMPANY NAME :** **PHONE NO.:**

SYSTEM FURNITURE					
NO.	ITEM		UNIT PRICE(US \$)	QTY	PRICE
3.21	Pegboard (L)(exclude hook) 90X180cm/H	Pc	42		
3.22	Hook for <input type="checkbox"/> Grid/ Wire Mesh <input type="checkbox"/> Pegboard 5cm	Pc	1		
3.23	Hook for <input type="checkbox"/> Grid/ Wire Mesh <input type="checkbox"/> Pegboard 10cm	Pc	1		
3.24	Hook for <input type="checkbox"/> Grid/ Wire Mesh <input type="checkbox"/> Pegboard 15cm	Pc	1		
3.25	System Partition 100x250cm/H	Pc	16		
3.26	Wooden Door 100x200cm/H	Pc	125		
3.27	Folding Door 100x200cm/H	Pc	29		
3.28	Coat Rack	Pc	21		
3.29	Wooden tall showcase 100X50X190cm/H (lock down, LEDX8 / including socket x1) <input type="checkbox"/> black <input type="checkbox"/> Ivory <input type="checkbox"/> white <input type="checkbox"/> B <input type="checkbox"/> D	pc	268		
3.30	Wooden table showcase 100X50X105cm/H (lock down, LEDX2,T5x1 / including socket x1) <input type="checkbox"/> black <input type="checkbox"/> Ivory <input type="checkbox"/> white <input type="checkbox"/> B <input type="checkbox"/> D	pc	180		
3.31	Wooden tall showcase 50X50X190cm/H (LEDX8 / including socketx1) <input type="checkbox"/> black <input type="checkbox"/> Ivory <input type="checkbox"/> white <input type="checkbox"/> B <input type="checkbox"/> D	pc	160		

FURNITURE					
NO.	ITEM		UNIT PRICE(US \$)	QTY	PRICE
3.32	Bar Stool <input type="checkbox"/> wine glass shape <input type="checkbox"/> S shape <input type="checkbox"/> Black <input type="checkbox"/> Red	Pc	29		
3.33	Single Cube Sofa 50×50×50cm/H <input type="checkbox"/> White <input type="checkbox"/> Black	Pc	21		
3.34	Bar Stool (Black)	Pc	21		
3.35	Bar Table Dia 60×110cm/H	Pc	29		
3.36	Meeting Table Dia.75X75cm/H	Pc	18		
3.37	Folding Chair 50×40×45cm/H (Black)	Pc	3		
3.38	Labofa Chair <input type="checkbox"/> White <input type="checkbox"/> Black <input type="checkbox"/> Red <input type="checkbox"/> Blue	Pc	18		

ELECTRICITY & LIGHTING (power consumption excluded)					
NO.	ITEM		UNIT PRICE(US \$)	QTY	PRICE
4.1	Yellow Spotlight 10W LED	Pc	12		
4.2	White Spotlight 10W LED	Pc	12		
4.3	Arm Yellow Spotlight 10W LED	Pc	15		
4.4	Arm White Spotlight 10W LED	Pc	15		
4.5	Yellow Spotlight 52W LED	Pc	30		
4.6	White Spotlight 52W LED	Pc	30		
4.7	Arm Yellow Spotlight 52W LED	Pc	33		
4.8	Arm White Spotlight 52W LED	Pc	33		
4.9	10W LED Spotlight	Pc	29		
4.10	10W LED Arm Spotlight	Pc	31		
4.11	Halogen Light 5W LED (<input type="checkbox"/> White/ <input type="checkbox"/> Yellow)(pls select)	Pc	29		
4.12	Socket 220V/5A	Pc	16		

Note : 1. A 30% surcharge will occur for orders received after the deadline (30 days prior to fair opening) and 50% surcharge will apply with onsite orders. 2.Order won't be completed without Form P.17-20. 3. Other Service please contact us. e-mail: twtc@interplan.com.tw

D. Additional Order Form 3

FAIR :

BOOTH NO. :

PHONENO. :

ELECTRICITY & LIGHTING (power consumption excluded)					
NO.	ITEM		UNIT PRICE(US \$)	QTY	PRICE
4.13	Socket 110V/5A	Pc	9		
4.14	Fl. Tube 14W	Pc	11		
ELECTRICITY & LIGHTING (power consumption excluded)					
NO.	ITEM		UNIT PRICE(US \$)	QTY	PRICE
4.16	Water Dispenser, Show period, including 3 bottles of water and socket	Pc	87		
4.17	Sink (rental fee includes cost of sink plus installation of sink to pipeline.) (Exhibitors should apply for water / drainage installation to Technical Support Section of TAITRA in advance)	Pc	161		
4.18	42"Plasma Show period, including socket	Pc	276		
4.19	19"LCD Monitor Show period, including socket	Pc	70		
4.20	DVD Player Show period, including socket	Pc	21		
4.21	Refrigerator 50x50x75cm/H, including socket	Pc	121		
GRAPHICS					
NO.	ITEM		UNIT PRICE(US \$)	QTY	PRICE
5.1	LOGO Print Out (5mm Foam) (30x30CM/H,File format: cdr or ai)	Pc	11		
5.2	PVC Sticker on Partition or Display Counter	SQM	12		
5.3	Poster Print Out 100x150CM/H (File format: cdr or ai)	Pc	76		
5.4	Styrofoam (Thick=3cm,H=30cm,including single PVC color selected, File format: cdr or ai)	Per word	14		
OTHERS					
NO.	ITEM		UNIT PRICE(US \$)	QTY	PRICE
6.1	Company Fascia Board High 300*100CM/H	Set	54		
6.2	A4 Brochure Stand □ Acrylic Rack □ Stand	Pc	29		
6.3	Plant (S) (30-50CM/H)	Set	4		
6.4	Plant (M) (60-90CM/H)	Set	6		
SUBTOTAL			US\$		
30% SURCHARGE (if order placed WITHIN 30 DAYS PRIOR to the show)			US\$		
5% VAT			US\$		
TOTAL			US\$		

(Order won't be completed without Form P.17-20)

Please Fill in Below Information :

COMPANY NAME : _____

ADDRESS : _____

© Orders are valid only when accompanied with full payment by telegraphic transfer.The invoice must be paid in full immediately upon faxed receipt.Complete payment in advance as a pre-condition of hand-over of the stands.

© TERMS of PAYMENT:

BANK NAME : MEGA INTERNATIONAL COMMERCIAL
BANK WORLD TRADE CENTER BRANCH
BENEFICIARY : INTERPLAN INTERNATIONAL CORPORATION
ACCOUNT No. : 21653023111 SWIFT CODE: ICBCTWTP216
ADDRESS: NO.333 KEELUNG ROAD, SEC.1 TAIPEI, TAIWAN, REPUBLIC OF CHINA

© A 30% surcharge will occur for orders received after the deadline

(30 days prior to fair opening) and 50% surcharge will apply with onsite orders.

© An administration fee of 30% of total amount will be charged,

if order is cancelled within 14 days before fair opening. No refund will be made for on-site cancellation.

© If you require a customized design for your booth, Please contact us via phone +886-2-2722-7777 / e-mail: twc@interplan.com.tw

**COMPANY STAMP/SIGNATURE/
DATE:**

D. Additional Order Form 4

Please mark your desired installation in approximate position in the following grid.

Please let us know how you would like to arrange the furniture in the booth. Please illustrate the location of each item you order on the grid to let us know how you want your stand be installed. if you order shelves, please kindly note the height and the quantity.

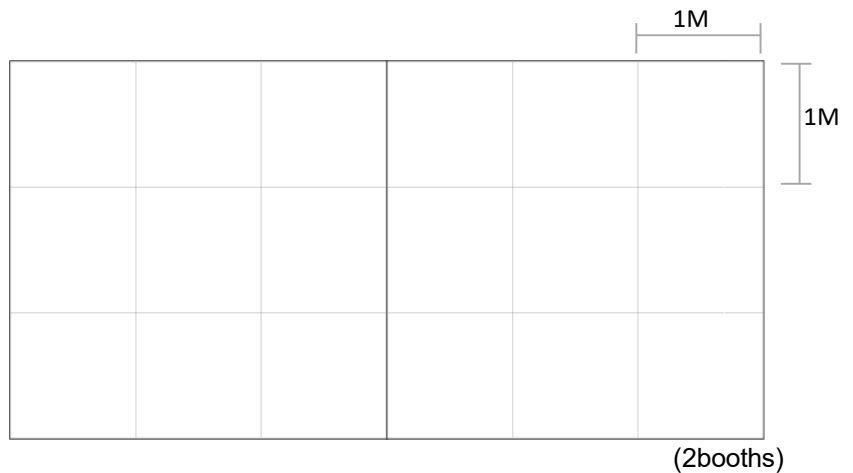

Example

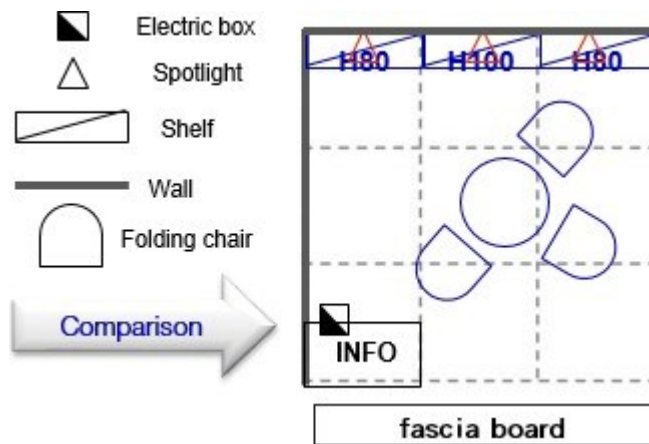

Please Fill in your booth number and company name on fascia board

(Letter Type : Arial Black)

FAIR : _____

COMPANY NAME : _____ BOOTH NO. : _____

CONTACT NAME : _____ PHONE NO. : _____

FAX : _____

E-MAIL ADDRESS : _____ COMPANY STAMP
SIGNATURE/ DATE: _____

E. Other Service

Interplan has been staging encounters between people and brands at events, road shows, trade fairs, and showrooms. We provide services ranging from event organizing, design creation content to event management worldwide. Our job is to develop incisive images, emotions and encounters that fit these goals, and to create messages that are not forgotten. Our expertise in sophisticated, creative approach to live events results from the thorough understanding to integrated marketing communications, including strategic planning, consumer communication, event marketing, trade shows, product launch, press conferences, grand openings, gala dinners. We can turn your brand message into an effective live event for your customers. Interplan develops Live Communication with measurable results and create experiences which amaze, fascinate and inspire.

Service Contact : +886 2 2722 7777 / +886 2 2758 5450
e-mail: twtc@interplan.com.tw



The thoughts, ideas, suggestions and advertising material presented in this concept are subject to the applicable copyright laws and are the intellectual property of Interplan International Corporation. Implementation of ideas and / or ideas relating to this concept requires the previous contractual consent of the holder of these rights. Reproduction of these concepts, either in whole or in part, as well as any transfer of these concepts to third parties is not allowed, insofar as it is not necessary for reaching a decision in the scope of this presentation. The recipient of this concept is liable for any damages resulting from the unauthorized use of this concept or the transfer of this concept. Through his acceptance, the recipient of this concept confirms that he will treat the ideas and suggestions mentioned therein as confidential.

Interplan International Corporation Rm. 408, No. 333, Keelung Rd Sec. 1. Taipei 110 Taiwan Tel: +886 2 2758 5450 Fax: +886 2 2729 3455

O'YA DESIGN

Create the new exhibition value, make each performance unexceptionable

O'YA has extensive experience of exhibition, research materials innovation and investment in the most advanced technology that will save energy and reduce carbon used in various display devices. Also,we make every effort to innovate and combine and integrate the material ingeniously and provide both practical and aesthetic Deco.In response to environmental protection and promote green exhibition,O'YA build a green exhibition cities jointly.The core competence of O'YA is to continue and extend the spirit of the brand,create the topic programming design and links,allow visitors to experience the product's performance easier.The service including:

- Exhibition planning and execution · Corporate identity systems · Retail sales · Flagship store concept exhibition
- Event planning and execution · Marketing and creative strategy planning · The promotion of art exhibitions ·

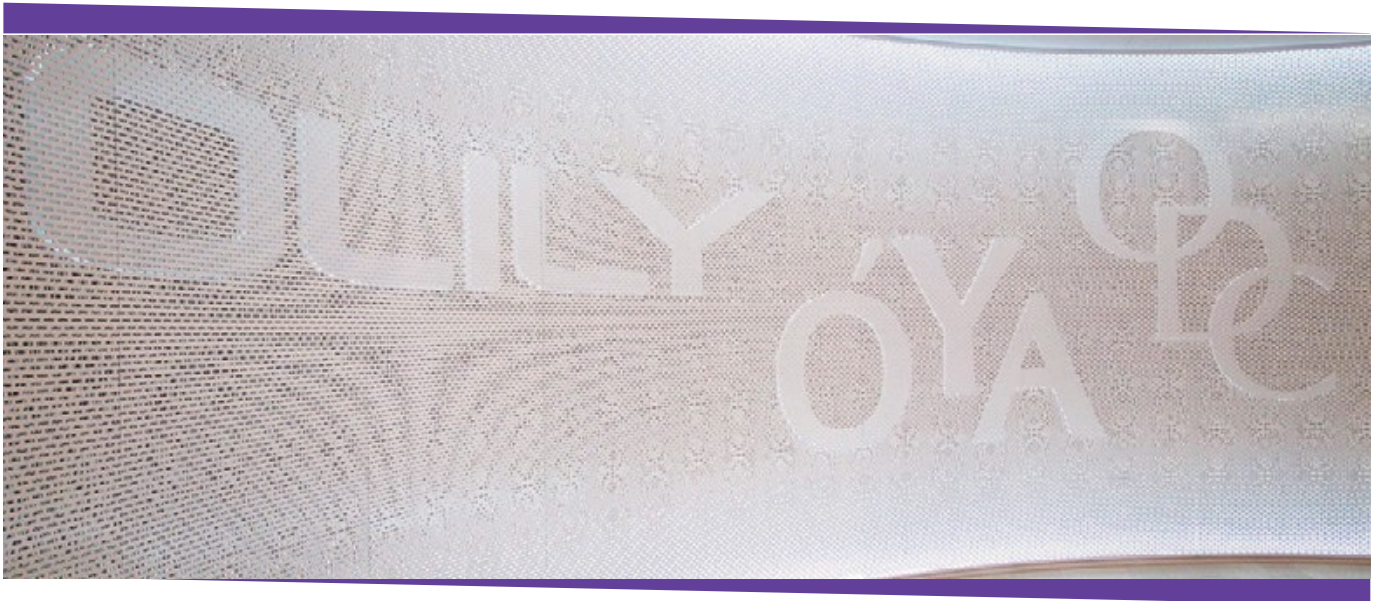

Booth : **A1** (9 SQM Booth) Price : NT\$ 4,200 (excluding 5% VAT)

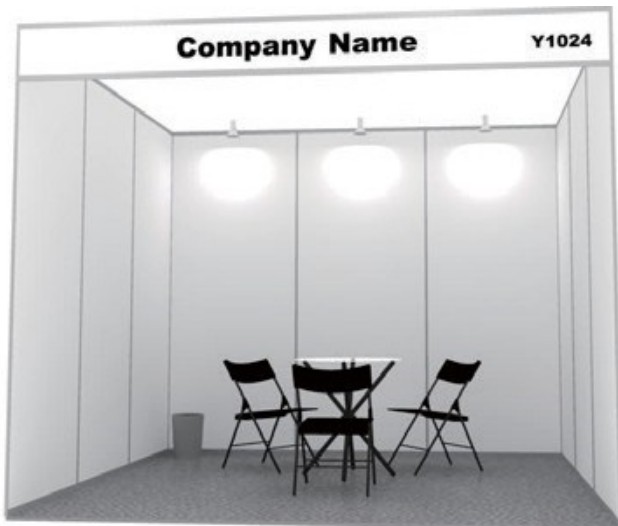

NO.	Item	Qty	Unit
1	System partition 300X300XH250CM	1	Set
2	Company name fascia board W300H30CM	1	Set
3	Needle punch carpet	9	Sqm
4	Glass Round Table Ø75CMxH73CM	1	Pc
5	Folding Chair	3	Pcs
6	Socket 110V / 500W	1	Pc
7	10W LED Spotlight(warm light)	3	Pcs
8	Trash can	1	Pc
Additional furniture rental please fill in Form 2 (P.10-P.13)			

Note : All items are on rental basis, will not be refunded or exchanged.

Booth : **A2** (18 SQM Booth) Price : NT\$ 8,200 (excluding 5% VAT)

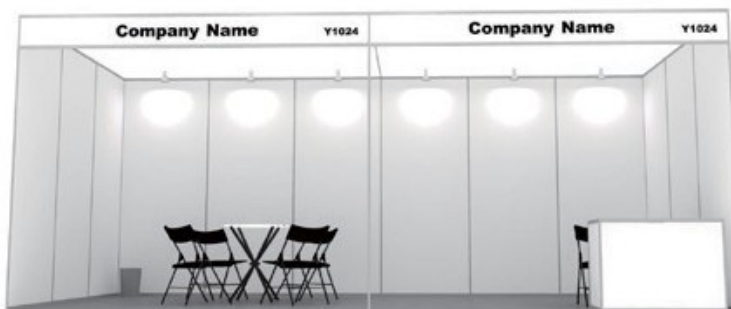

NO.	Item	Qty	Unit
1	System partition 600X300XH250CM	1	Set
2	Company name fascia board W300H30CM	2	Set
3	Needle punch carpet	9	Sqm
4	Glass Round Table Ø75CMxH73CM	1	Pc
5	Folding Chair	3	Pcs
6	Information counter W100D50H75CM	1	Pc
7	Socket 110V / 500W	1	Pc
8	10W LED Spotlight(warm light)	3	Pcs
9	Trash can	1	Pc
Additional furniture rental please fill in Form 2 (P.10-P.13)			

Note : All items are on rental basis, will not be refunded or exchanged.

Please choose the color of PVC cutting graphic for company name & logo using, and complete P.11 or black letter on white board will be used.

Black Red Blue Green

Notice

1. Exhibitors who do not use any of the standard equipment shall consider it waived and furniture replacement will not be accepted.
2. Additional furniture rental will require both the application form (page 9-12) and a booth layout beingsubmitted.
3. Nothing may be stuck, screwed, or nailed to the stand. Nor may it be painted, modified or damaged. You may mount posters using Powerstrips® or similar material, which does not leave any sticky residue upon removal.

Should you require a customized design for your booth, O'YA will be pleased to assist.

Booth : **A3** (9 SQM Booth) Price : NT\$ 10,000 (excluding 5% VAT) (poster & graphic excluded)



NO.	Item	Qty	Unit
1	System partition 300X300XH250CM	1	Pc
2	Company name fascia board H100CM (Including PVC cutting company name & logo)	1	Pc
3	Needle punch carpet	9	Sqm
4	Glass Round Table Ø75CMxH73CM	1	Pc
5	Folding Chair	3	Pcs
6	Information counter W100D50H75CM	1	Pc
7	1/4 Round Display Platform W50H75CM	1	Pc
8	10W LED Spotlight(warm light)	3	Pcs
9	Trash can	1	Pc
Additional furniture rental please fill in Form 2 (P.10-P.13)			

Note : All items are on rental basis, will not be refunded or exchanged.

Booth : **A4** (9 SQM Booth) Price : NT\$ 15,000 (excluding 5% VAT) (poster & graphic excluded)



NO.	Item	Qty	Unit
1	System partition 300X300XH250CM	1	Pc
2	Company name fascia board H75CM (Including PVC cutting company name & logo)	1	Pc
3	Rounding LOGO H110CM (shaping foam board)	1	Pc
4	Needle punch carpet	9	Sqm
5	Information counter W100D50H75CM	1	Pc
6	Folding Chair	2	Pcs
7	Socket 110V/500W	1	Pc
8	10W LED Spotlight & Arm Light (warm light)	3	Pcs
9	10W LED Spotlight & Arm Light (warm light)	2	Pcs
10	Trash can	1	Pc
Additional furniture rental please fill in Form 2 (P10-P.13)			

Note : All items are on rental basis, will not be refunded or exchanged.

Please choose the color of PVC cutting graphic for company name & logo using, and complete P.11 or black letter on white board will be used.

Black Red Blue Green

To place your order, please choose the color of carpet and complete P.11 or the Gray one will be used.

Gray Red Blue

Should you require a customized design for your booth, O'YA will be pleased to assist.

Design Scheme Booth

Booth : **B1** (18 SQM Booth) Price : NT\$ 22,500 (excluding 5% VAT) (poster & graphic excluded)



NO.	Item	Qty	Unit
1	System partition 600X300XH250CM	1	Pc
2	Fascia board H100CM (Including PVC cutting Company Name and Logo)	1	Pc
3	Needle punch carpet	18	Sqm
4	Display Platform W100D50H75CM	1	Pc
5	Glass Round Table Ø75CMxH73CM	1	Pc
6	Folding Chair	4	Pcs
7	Socket 110V/500W	1	Pc
8	10W LED Spotlight(warm light)	10	Pcs
9	Trash can	1	Pc
Additional furniture rental please fill in Form 2 (P.10-P.13)			

Note : All items are on rental basis, will not be refunded or exchanged.

Early Bird News

Confirm **before 45 Days** will offer Storage with the size 1MX1MXH2.5M

Or W100cm showcase with lock for **Free**
(Cannot be discounted in cash)

Booth : **B2** (18 SQM Booth) Price : NT\$ 30,000 (excluding 5% VAT) (poster & graphic excluded)



NO.	Item	Qty	Unit
1	System partition 600X300XH250CM	1	Pc
2	Company Name Fascia board H100&H150CM (Including PVC cutting company name and logo)	1	Pcs
3	Needle punch carpet	18	Sqm
4	Glass Round Table Ø75CMxH73CM	1	Pc
5	Folding Chair	4	Pcs
6	Display Platform W100D50H75CM&H100CM(with lock)	1	Pc
7	Information counter W100D50H100CM	1	Pc
8	Socket 110V/500W	1	Pc
	9 Storge Partition W100D100H250CM	1	Pc
10	10W LED Spotlight (warm light)	5	Pcs
11	10W LED Arm Light (warm light)	6	Pcs
12	Trash can	1	Pc
Additional furniture rental please fill in Form 2 (P.10-P.13)			

Note : All items are on rental basis, will not be refunded or exchanged.

Early Bird News

Confirm **before 45 Days** will offer Storage with the size 1MX1MXH2.5M

Or W100cm showcase with lock for **Free**
(Cannot be discounted in cash)

To place your order, please choose the color of carpet and complete P.11 or the Gray one will be used.

Gray Red Blue

Should you require a customized design for your booth, O'YA will be pleased to assist.

Package Scheme Booth

Booth : **C1** (36 SQM Booth) Price : NT\$ 38,000 (excluding 5% VAT) (poster & graphic excluded)



NO.	Item	Qty	Unit
1	System partition 600X100XH250CM	1	Pc
2	Company Name Fascia board W600H150CM (Including PVC cutting company name and logo)	1	Pc
3	Needle punch carpet	36	Sqm
4	Glass Round Table Ø75CMxH73CM	3	Pc
5	Folding Chair	9	Pcs
6	Information counter W100D50H100CM (Including PVC cutting "INFORMATION")	1	Pc
7	Low Glass Showcase W100D50H100CM (with lock \ no light)	2	Pcs
8	Low Glass Showcase W100D50H125CM (with lock \ no light)	1	Pc
9	1/2 Round Display Platform W100D50H75CM&H100CM	1	Pc
10	10W LED Arm Light (warm light)	6	Pcs
11	Trash can	1	pc
Additional furniture rental please fill in Form 2 (P.10-P.13)			

Note : All items are on rental basis, will not be refunded or exchanged.

Booth : **C2** (36 SQM Booth) Price : NT\$ 50,000 (excluding 5% VAT) (poster & graphic excluded)



NO.	Item	Qty	Unit
1	System partition 600X100XH250CM	1	Pc
2	Company Name Fascia board W600H100CM (Including PVC cutting company name and logo)	1	Pc
3	Needle punch carpet	36	Sqm
4	Glass Round Table Ø75CMxH73CM	2	Pc
5	Folding Chair	8	Pcs
6	Low Glass Showcase(with lock & LED Light*2)	2	Pcs
7	Arc Round Platform H100CM	2	Pcs
8	Storge Partition W200D100H250CM	1	Pc
9	1/4 Round Display Platform	2	Pcs
10	Display Platform W100D50H75CM&H100CM	1	Pc
11	Square Display Platform W50D50H100CM	2	Pcs
12	Socket 110V/500W	1	Pc
13	10W LED Arm Light (warm light)	12	Pcs
14	Trash can	1	Pc
Additional furniture rental please fill in Form 2 (P.10-P.13)			

Note : All items are on rental basis, will not be refunded or exchanged.

Early Bird News

Confirm **before 45 Days** will offer Storage with the size 1MX1MXH2.5M

Or W100cm showcase with lock for **Free**
(Cannot be discounted in cash)

Please choose the color of PVC cutting graphic for company name & logo using, and complete P.11 or black letter on white board will be used.

Black Red Blue Green

To place your order, please choose the color of carpet and complete P.11 or the Gray one will be used.

Gray Red Blue

Should you require a customized design for your booth, O'YA will be pleased to assist.

Booth : **D1** (18 SQM Booth) Price : NT\$ 45,000 (excluding 5% VAT)



Early Bird News

Confirm **before 45 Days** will offer Storage with the size 1MX1MXH2.5M

Or W100cm showcase with lock for **Free**
(Cannot be discounted in cash)

NO.	Item	Qty	Unit
1	System partition 600X300XH250CM	1	Pc
2	Fascia Board H120CM (Including PVC cutting company name and logo)	1	Pc
3	1/4 Round Board H150CM (Including PVC cutting Website address)	2	Pcs
4	Needle punch carpet	18	Sqm
5	Glass Round Table Ø75CMxH73CM	1	Pc
6	Folding Chair	4	Pcs
7	Arc-shaped Information counter W150D50H100CM (Including PVC cutting "INFORMATION")	1	Pc
8	Display Platform (including lock) W100D50H75CM	3	Pcs
9	Flat Wooden Shelf W100D30CM	3	Pcs
10	1/4 Round High Glass Showcase W50D50H250CM (with lock 、 glass shelf*2 、 10W downlight*1)	2	Pcs
11	10W LED Spotlight (warm light)	10	Pcs
12	Trash can	1	pc
Additional furniture rental please fill in Form 2 (P.10-P.13)			

Note : All items are on rental basis, will not be refunded or exchanged.

Booth : **D2** (18 SQM Booth) Price : NT\$ 33,000 (excluding 5% VAT) (poster & graphic excluded)



Early Bird News

Confirm **before 45 Days** will offer Storage with the size 1MX1MXH2.5M

Or W100cm showcase with lock for **Free**
(Cannot be discounted in cash)

NO.	Item	Qty	Unit
1	System partition 600X300XH250CM	1	Pc
2	Fascia Board H100CM (Including PVC cutting company logo)	1	Pc
3	Needle punch carpet	18	Sqm
4	Display Platform W100D50H100CM	2	Pcs
5	Display Platform (including lock) W100D50H75CM	2	Pc
6	1/4 Round High Glass Showcase W150D50H250CM (with lock 、 glass shelf*2 、 10W downlight*1)	1	Pc
7	Display Platform W50D50H100CM	2	Pcs
8	Glass Round Table Ø75CMxH73CM	2	Pc
9	Folding Chair	8	Pcs
10	Socket 110V/500W	1	Pc
11	10W LED Spotlight	8	Pcs
12	Trash can	1	Pc
Additional furniture rental please fill in Form 2 (P.10-P.13)			

Note : All items are on rental basis, will not be refunded or exchanged.

Please choose the color of PVC cutting graphic for company name & logo using, and complete P.11 or black letter on white board will be used.

Black Red Blue Green

To place your order, please choose the color of carpet and complete P.11 or the Gray one will be used.

Gray Red Blue

Should you require a customized design for your booth, O'YA will be pleased to assist.

Booth : **D3** (18 SQM Booth) Price : NT\$ 32,000 (excluding 5% VAT) (poster & graphic excluded)

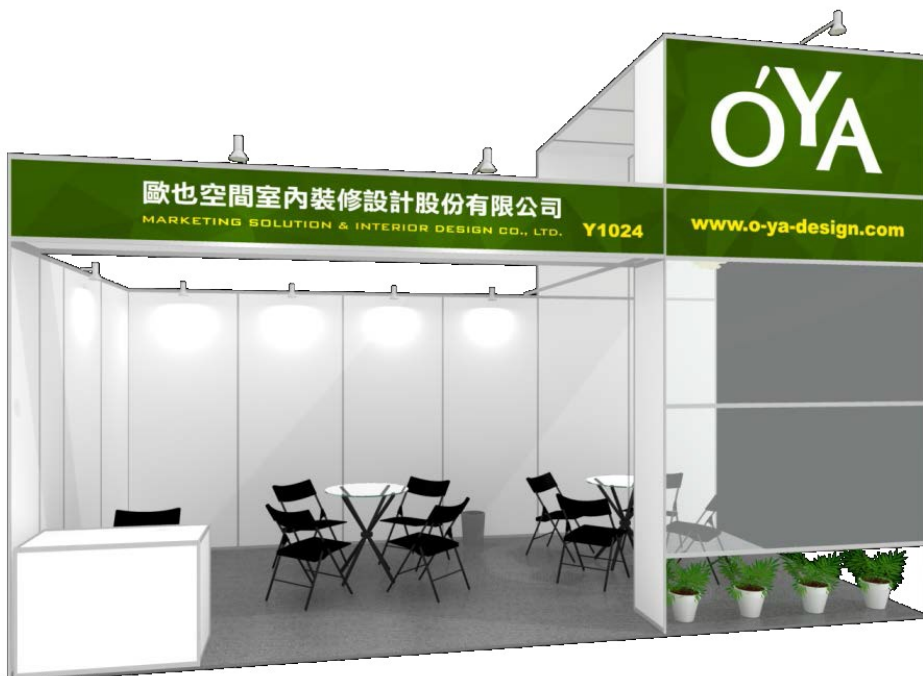

NO.	Item	Qty	Unit
1	System partition 600X300XH250CM	1	Pc
2	Fascia Board H50&H100CM (Including PVC cutting company name and logo)	1	Pc
3	Needle punch carpet	18	Sqm
4	Information counter W100D50H75CM	1	Pc
5	Glass Round Table Ø75CMxH73CM	2	Pcs
6	Folding Chair	9	Pcs
7	Socket 110V/500W	2	Pcs
8	10W LED Arm Light (warm light)	5	Pcs
9	10W LED Spotlight (warm light)	5	Pcs
10	Candelier(warm light)	2	Pcs
11	Trash can	1	Pc

Additional furniture rental please fill in Form 2 (P.10-P.13)

Note : All items are on rental basis, will not be refunded or exchanged.

Early Bird News

Confirm **before 45 Days** will offer Storage with the size 1MX1MXH2.5M

Or W100cm showcase with lock for **Free**
(Cannot be discounted in cash)

Please choose the color of PVC cutting graphic for company name & logo using, and complete P.11 or black letter on white board will be used.

Black Red Blue Green

To place your order, please choose the color of carpet and complete P.11 or the Gray one will be used.

Gray Red Blue

Should you require a customized design for your booth, O'YA will be pleased to assist.

Design Scheme Booth

Booth : **E1** (18 SQM Booth) Price : NT\$ 25,000 (excluding 5% VAT) (poster & graphic excluded)



NO.	Item	Qty	Unit
1	System partition 600X300XH250CM	1	Pc
2	Fascia board H25CM (Including PVC cutting Website address)	1	Pc
3	18W downlight for Company Name Fascia board	6	Pcs
4	Company Name Fascia board H75CM (Including PVC cutting company name and logo)	1	Pc
5	Needle punch carpet	18	Sqm
6	Glass Round Table Ø75CMxH73CM	1	Pc
7	Folding Chair	4	Pcs
8	Square Display Platform W50D50H100CM	2	Pc
9	Square Display Platform W50D50H75CM	6	Pcs
10	10W LED Spotlight(warm light)	6	Pcs
11	Trash can	1	pc

Additional furniture rental please fill in Form 2 (P.10-P.13)

Note : All items are on rental basis, will not be refunded or exchanged.

Early Bird News

Confirm **before 45 Days** will offer
Storage with the size 1MX1MXH2.5M

Or W100cm showcase with lock for **Free**
(Cannot be discounted in cash)

Booth : **E2** (18 SQM Booth) Price : NT\$ 35,000 (excluding 5% VAT) (poster & graphic excluded)



NO.	Item	Qty	Unit
1	System partition 600X300XH400CM	1	Pc
2	Company Name Fascia board H100+50CM (Including PVC cutting company name and logo)	1	Pcs
3	Needle punch carpet	18	Sqm
4	Storage room W200D100H250CM	1	Pc
5	Wooden Door W100H200+50CM	1	Pc
6	Glass Round Table Ø75CMxH73CM	1	Pc
7	Folding Chair	4	Pcs
8	Information counter W100D50H100CM	1	Pc
9	Display Platform (including lock) W100D50H100CM	2	Pcs
10	10W LED Arm Light (warm light)	6	Pcs
11	10W LED Downlight (warm light)	10	Pcs
12	Trash can	1	Pcs

Additional furniture rental please fill in Form 2 (P.10-P.13)

Note : All items are on rental basis, will not be refunded or exchanged.

Early Bird News

Confirm **before 45 Days** will offer W100cm showcase with lock for **Free**
(Cannot be discounted in cash)

Please choose the color of PVC cutting graphic for company name & logo using, and complete P.11 or black letter on white board will be used.

Black Red Blue Green

To place your order, please choose the color of carpet and complete P.11 or the Gray one will be used.

Gray Red Blue

Should you require a customized design for your booth, O'YA will be pleased to assist.

Form1 Application Plan layout

- ※A 30% surcharge will occur for orders received after the deadline (30~15 days before fair opening)
- ※50% surcharge will occur for orders received after the deadline (14 days before fair opening) and need to pay by cash directly.
- ※Order won't be completed without Form P.10-P.13.

Show Name : _____ Company Name : _____ Booth Number : _____

1. Company Fascia Board : Please fill in company name.

2. Please mark your desired installation in approximate position in the following grid.

(1) This plan contains 6 booths, each 3 by 3 grid stands for 3*3M booth, please kindly mark your booth type and location.

(2) Please draw stand showing desired installation here or enclose drawing on separate sheet. If you order shelves, please note the height and amount of the shelves you requested.

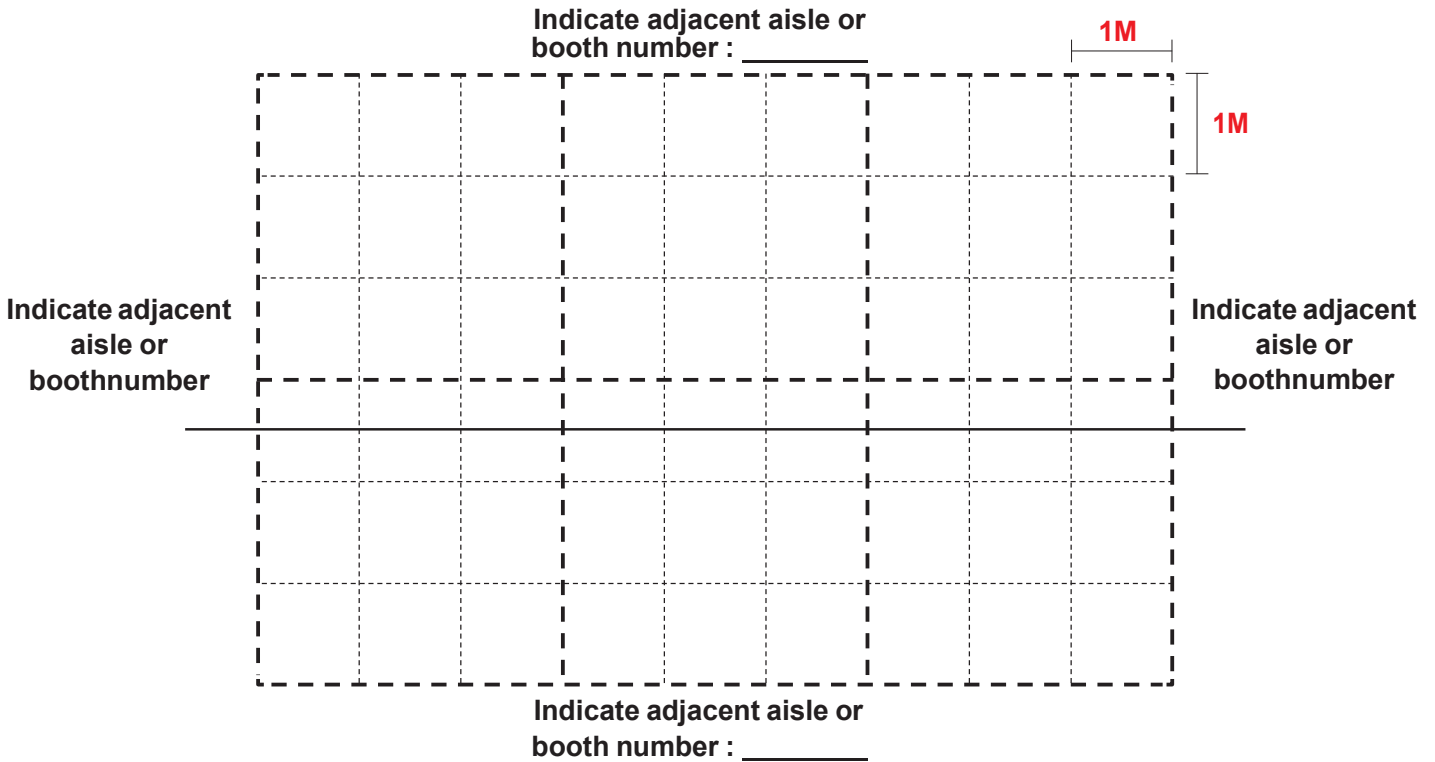

Example



- Spot Light
- ▭ Flat Wooden Shelf (H : 100CM)
- Folding Chair
- 110V / 5A Socket
- INFO H:75cm
- H:75cm
- Information counter W100D50H75CM
- Rectangle Display Platform W100D50H75CM

Comparison

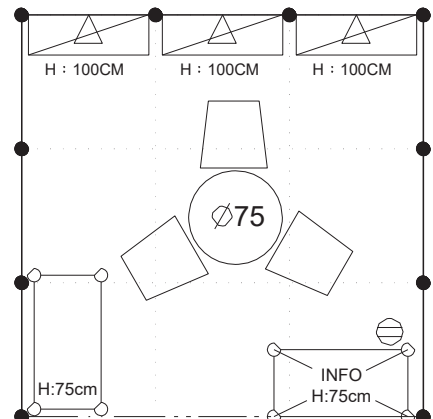

Form2-1 Additional Furniture Form

※A 30% surcharge will occur for orders received after the deadline (30~15 days before fair opening)
 ※50% surcharge will occur for orders received after the deadline (14 days before fair opening) and need to pay by cash directly.
 ※Order won't be completed without Form P.10-P.13.

Show Name : _____ Company Name : _____ Booth Number : _____

NO	ITEM	DIMENSION	UNIT PRICE(NT\$)	QTY	PRICE(NT\$)
Booth Type					
A1	Cmpany name color _____	Please refer to Booth A1	4,200		
A2	Cmpany name color _____	Please refer to Booth A2	8,200		
A3	Cmpany name color _____ \ Carpet color _____	Please refer to Booth A3	10,000		
A4	Cmpany name color _____ \ Carpet color _____	Please refer to Booth A4	15,000		
B1	Cmpany name color _____ \ Carpet color _____	Please refer to Booth B1	22,500		
B2	Cmpany name color _____ \ Carpet color _____	Please refer to Booth B2	30,000		
C1	Cmpany name color _____ \ Carpet color _____	Please refer to Booth C1	40,000		
C2	Cmpany name color _____ \ Carpet color _____	Please refer to Booth C2	50,000		
D1	Cmpany name color _____ \ Carpet color _____	Please refer to Booth D1	45,000		
D2	Cmpany name color _____ \ Carpet color _____	Please refer to Booth D2	37,600		
D3	Cmpany name color _____ \ Carpet color _____	Please refer to Booth D3	32,000		
E1	Cmpany name color _____ \ Carpet color _____	Please refer to Booth E1	25,000		
E2	Cmpany name color _____ \ Carpet color _____	Please refer to Booth E2	35,000		
Should you require a customized design for your booth, please contact us via phone or e-mail.					
SYSTEM FURNITURE					
1.1	Information counter	W100D50H75CM	500		
1.2	Information counter	W100D50H100CM	600		
1.3	Rectangle Display Platform	W100D50H50CM	500		
1.4	Rectangle Display Platform	W100D50H75CM	500		
1.5	Rectangle Display Platform	W100D50H100CM	600		
1.6	Square Display Platform	W50D50H50CM	400		
1.7	Square Display Platform	W50D50H75CM	450		
1.8	Square Display Platform	W50D50H100CM	500		
1.9	Square Display Platform	W100D100H75CM	750		
1.10	Square Display Platform	W100D100H100CM	850		
1.11	Display Platform	W100D50H50&H75CM	1,000		
1.12	Display Platform	W100D50H50&H100CM	1,200		
1.13	Display Platform	W100D50H75&H100CM	1,200		
1.14	Display Platform	W100D100H75&H100CM	1,600		
1.15	Display Platform (including lock)	W100D50H75CM	600		
1.16	Display Platform (including lock)	W100D50H100CM	750		
1.17	Flat Wooden Shelf	W100D30CM	150		
1.18	Slope Wooden Shelf	W100D30CM	200		
1.19	Glasss Shelf	W100D30CM	300		
1.20	1/4 Round Display Platform	W50xH75CM	600		
1.21	1/4 Round Display Platform	W50xH100CM	700		
1.22	Coat Hanger	W100D10CM	500		
1.23	Coat Hanger (beam)(A)	W100CM	450		
1.24	Coat Hanger (beam)(B)	W100H75/H100/H125/H150/ H200	650		
1.25	Partition board	W100H250CM	550		
1.26	Folding Door	W100H200+50CM	800		
1.27	Wooden Door	W100H200+50CM	2,200		
1.28	Low Glass Showcase (with lock & LED Light*2)	W100D50H100CM	2,500		

Form2-2 Additional Furniture Form

※A 30% surcharge will occur for orders received after the deadline (30~15 days before fair opening)

※50% surcharge will occur for orders received after the deadline (14 days before fair opening) and need to pay by cash directly.

※Order won't be completed without Form P.10-P.13.

Show Name : _____ Company Name : _____ Booth Number : _____

NO	ITEM	DIMENSION	UNIT PRICE(NT\$)	QTY	PRICE(NT\$)
1.29	High Glass Showcase (with lock、glass shelf*1、downlight*1)	W50D50H200CM	3,000		
1.30	High Glass Showcase (with lock、glass shelf*1、downlight*2)	W100D50H200CM	4,000		
1.31	Pegboard (S)(exclude hook)	W90H120CM	600		
1.32	Pegboard (L)(exclude hook)	W90H190CM	750		
1.33	Grid/Wire mesh (S)(exclude hook)	W90H120CM	750		
1.34	Grid/Wire mesh (L)(exclude hook)	W90H180CM	900		
1.35	Pegboard Hook	10CM	20		
1.36	Pegboard Hook	15CM	30		
1.37	Grid/Wire mesh Hook	10CM	20		
1.38	Grid/Wire mesh Hook	15CM	30		
1.39	Wall Mount wooden board (for TV)	W100H50CM	1,500		
TABLE & CHAIR					
2.1	Folding Chair (Black)	W50X50CM	70		
2.2	Meeting Chair		500		
2.3	Jess Chair □ White □ Black)		500		
2.4	Glass Round Table	Ø75CMxH73CM	500		
2.5	Bar Table(Black)	Ø60CMxH106CM	850		
2.6	Bar Stool (Black)	Ø40CM	400		
2.7	Bar Table(White)	Ø60CMxH97CM	1,100		
2.8	Bar Stool(White)	Ø40CMxH87.5CM	700		
2.9	Frosted Glass Round Table	Ø75CMxH73.5CM	1,100		
2.10	Frosted Glass Bar Table	Ø60CMxH106CM	1,100		
2.11	Bar Stool (White)	W36.5xH90CM	1,100		
2.12	Sofa (Square)	45.5x45.5xH37.5CM	700		
2.13	A4 brochure stand (vertical)	W30xH177CM	750		
ELECTRICITY & LIGHTING					
3.1	10W LED Spot Light	10W(warm light)	250		
3.2	10W LED Spot Light	10W(cool light)	300		
3.3	10W LED Arm Light	10W(warm light)	250		
3.4	10W LED Arm Light	10W(cool light)	300		
3.5	52W LED Spot	52W(warm / cool light)	860		
3.6	52W LED Arm Light	52W(warm / cool light)	860		
3.7	9W LED Spot Light	9W(warm light)	550		
3.8	9W LED Arm Light	9W(warm light)	600		
3.9	T5 Fluorescent Tube	21W(cool light)	250		
3.10	Socket	110V/500W	200		
3.11	Socket	110V/1000W	350		
3.12	Socket	110V/1500W	450		
3.13	Socket	220V/500W	450		
3.14	Socket	220V/1500W	600		
3.15	42" Plasma	Show period, including socket	8,000		
3.16	19" LCD Monitor	Show period, including socket	950		
3.17	Water Dispenser	Show period, including 3 bottles of water and socket	2,500		
3.18	Refrigerator	W48D54H86CM,including socket	3,500		

Form2-3 Additional Furniture Form

※A 30% surcharge will occur for orders received after the deadline (30~15 days before fair opening)
 ※50% surcharge will occur for orders received after the deadline (14 days before fair opening) and need to pay by cash directly.
 ※Order won't be completed without Form P.10-P.13.

Show Name : _____ Company Name : _____ Booth Number : _____

NO	ITEM	DIMENSION	UNIT PRICE(NT\$)	QTY	PRICE(NT\$)
Art production, poster output					
4.1	LOGO Print Out	H20CM/H,File format: cdr or ai	300		
4.2	Styrofoam (depending on the size quoted separately), File format: cdr or ai)				
4.3	PVC Sticker on Partition or Display Counter (depending on the size quoted separately)				
4.4	Poster	W90H120CM	1,440		
4.5	Poster + Foam	W90H120CM	1,620		
Should you need any other poster, please contact us.					
OTHERS					
5.1	Plant (S) (30-50CM/H)		100		
5.2	Plant (M) (60-90CM/H)		150		
SUBTOTAL					NTD
30% SURCHARGE (if order placed WITHIN 30 DAYS PRIOR to the show)					
5% VAT					
TOTAL					NTD

※All items are on rental basis

Company Name : _____

Address : _____

TEL : _____ FAX : _____ E-mail : _____

◎ Please kindly note that all payment for orders must reach us at the stipulated date (30 days before show open) or will be deemed as invalid. Methods of payment :

O'YA MARKETING SOLUTION AND INTERIOR DESIGN CO., LTD.

BANK : HUA NAN COMMERCIAL BANK, LTD CHIEN CHEN BRANCH

USD A/C : 105-97-000986-1

BANK Address : 38, Sec. 1, Chung-King South Road, Taipei, Taiwan, R.O.C.

SWIFT: HNBKTWTP105

O'YA MARKETING SOLUTION AND INTERIOR DESIGN CO., LTD.

BANK : HUA NAN COMMERCIAL BANK, LTD CHIEN CHEN BRANCH

TWD A/C : 105-10-027600-8

BANK Address : 38, Sec. 1, Chung-King South Road, Taipei, Taiwan, R.O.C.

SWIFT : HNBKTWTP105

**Please signature
by contact person**

◎ A 30% surcharge will occur for orders received after the deadline (30~15 days before fair opening) and 50% surcharge will occur for orders received after the deadline (14 days before fair opening) and need to pay by cash directly.

◎ Cancellation before 21 days from show open. Cancellation fee of 30% of book price will be charged accordingly.

No refund during the show.

- ⊙ Items will be supplied unless payment has been made and sufficient supply of items.
- ⊙ All items are on rental basis, will not be refunded or exchanged.
- ⊙ Please contact us for more services, incl. equipment rental, stand design and digital graphic design and printing.

Furniture, Electricity, Media, Graphics, and other equipment - 1

※Should you need other equipment, please contact us.

1.1 / 1.2

Information counter

接待桌

W100D50H75/H100CM

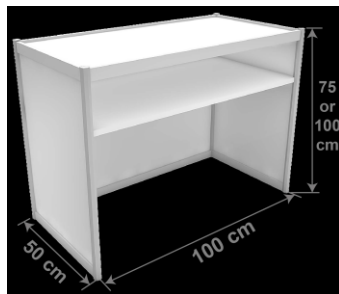

1.3 / 1.4 / 1.5

Rectangle Display Platform

長方形展示台(四面白色封板)

W100D50H50/H75/H100CM

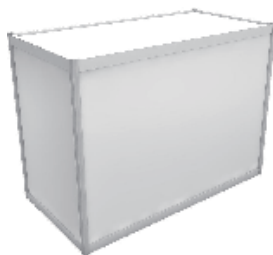

1.6 / 1.7 / 1.8

Square Display Platform

正方形展示台(四面白色封板)

W50D50H50/H75/H100CM



1.9 / 1.10

Square Display Platform

正方形展示台(四面白色封板)

W100D100H75/H100CM

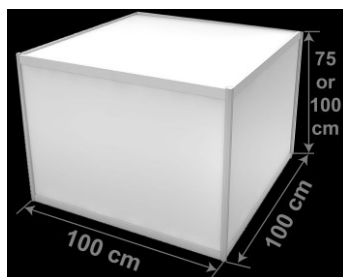

1.11 / 1.12

Stepped Display Platform

階梯展示台(四面白色封板)

W100D50H50&D50H75CM

W100D50H50&D50H100CM

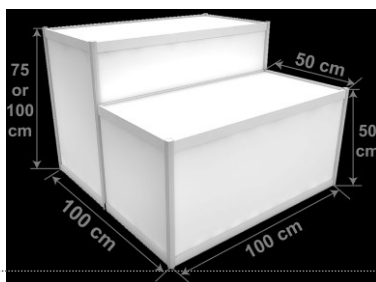

1.13

Stepped Display Platform

階梯展示台(四面白色封板)

W100D50H75&D50H100CM

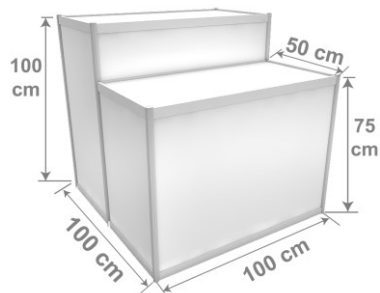

1.14

Stepped Display Platform

階梯展示台(四面白色封板)

W100D100H75&D100H100CM



1.15 / 1.16

Display Platform (including lock)

可鎖櫃

W100D50H75CM / H100CM



1.17 / 1.18

Wooden Shelf (Flat or Slope)

木製層板(平/斜)

W100D30CM



1.19

Glass Shelf

玻璃層板

W100D30CM



1.20 / 1.21

1/4 Round Display Platform

1/4圓展示台(三面白色封板)

W50H75CM / W50H100CM



1.22

Coat Hanger

組合衣架

W100D5CM



Furniture, Electricity, Media, Graphics, and other equipment - 2

※Shoud you need other equipment, please contact us.

1.23 / 1.24

Coat Hanger (beam)

圓型衣桿

W100D30CM
(含落地支撐結構
H75/H100/H125/
H150/H200CM)



1.25

Partition board

組合背板

W100H250CM



1.26

Folding Door

折門

W100H200+50CM



1.27

Wooden door

木門

W100H200+50CM



1.28

Low Glass Showcase

玻璃矮櫃 (附鎖、含櫃內珠寶燈

x2) (with lock & LED Lightx2)

W100D50H100CM



1.29

High Glass Showcase

玻璃高櫃 (附鎖、含玻璃層板 x1、黃光嵌燈

*1) (with lock、glass shelfx1、downlightx1)

W50D50H200CM



1.30

High Glass Showcase

玻璃高櫃 (附鎖、含玻璃層板 x1、黃光嵌燈*1)

(with lock、glass shelfx1、downlightx1)

W100D50H200CM



1.31 / 1.32

Peg Board (exclude hook)

外掛式洞洞板(掛勾另計)

W90H120CM / W90H190CM



1.33 / 1.34

Girdwiremesh (exclude hook)

鐵網(外掛式)(掛勾另計)

W90H120 / W90H180CM

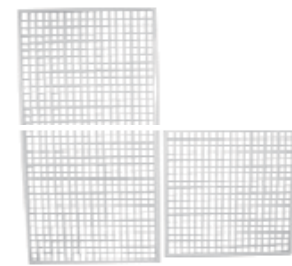

1.35 / 1.36

Peg Board Hook

洞洞板掛勾

10CM / 15CM



1.37 / 1.38

Grid/Wire mesh Hook

鐵網掛勾

10CM / 15CM



1.39

Wall Mount wooden board (for TV)

電視掛板

W100H50CM



Furniture, Electricity, Media, Graphics, and other equipment - 3

※Should you need other equipment, please contact us.

2.1

Folding Chair (Black)
黑色折椅
W50x50CM



2.2

Meeting Chair
布質會議椅



2.3

Jess Chair (White / Black)
傑斯椅 (白 / 黑)



2.4

Glass Round Table
玻璃圓桌
Ø70xH73CM



2.5

Bar Table (Black)
黑色高吧桌



Ø60CMxH106CM

2.6

Bar Stool (Black)
黑色高吧椅
Ø40CM



2.7

Bar Table (White)
白色高吧桌
Ø60CMxH97CM



2.8

Bar Stool (White)
白色氣壓式高吧椅
Ø40CMxH87.5CM



2.9

Bar Table (White)
磨砂圓桌
Ø75CMxH73.5CM



2.10

Bar Table (White)
磨砂高吧桌
Ø60CMxH106CM



2.11

Bar Stool (White)
大方吧椅
W36.5x78.5CM ·
H90CM(降低 68CM)



2.12

Sofa (Square)
方型豆腐沙發



Furniture, Electricity, Media, Graphics, and other equipment - 4

※Should you need other equipment, please contact us.

2.13

A4 brochure stand (vertical)
A4 目錄架 (直立式)



Sofa
單人沙發



(如有需求，請洽專案窗口)
(Should you have any need, please contact us)

Meeting table

會議長桌



W180D60H74CM



W120D60H74CM

(如有需求，請洽專案窗口)
(Should you have any need, please contact us)

Coat Hanger

ㄇ型衣架

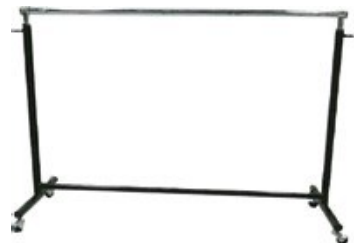

(如有需求，請洽專案窗口)
(Should you have any need, please contact us)

Extendable railing

伸縮銅柱

W180H100CM



(如有需求，請洽專案窗口)
(Should you have any need, please contact us)

Velvet rope

紅龍柱

W100H100CM



(如有需求，請洽專案窗口)
(Should you have any need, please contact us)

Poster stand (S)

海報指示架



(如有需求，請洽專案窗口)
(Should you have any need, please contact us)

3.1 / 3.2

10W LED Spot Light

(warm / cool light)

10W LED 節能投光燈 (黃光 / 白光)



3.3 / 3.4

10W LED Arm Light

(warm / cool light)

10W LED 節能長柄燈 (黃光 / 白光)



3.5 / 3.6

52W LED Spot (Arm) Light

(warm / cool light)

52W LED 投光(長柄)燈 (黃光/白光)



3.7

9W LED Spot Light (warm light)

9W LED 聚光投光燈 (黃光)



3.8

9W LED Arm Light (warm light)

9W LED 聚光長柄燈 (黃光)



Furniture, Electricity, Media, Graphics, and other equipment - 5

※Should you need other equipment, please contact us.

3.9

T5 21W Fluorescent Tube (cool light)
T5 21W 日光燈 (白光)



150W HQI Spot Light (cool light)
150W HQI 投光燈 (白光)



(如有需求·請洽專案窗口)

(Should you have any need, please contact us)

3.10-3.14

Socket
插座
110V-500W / 1000W / 1500W
220V-500W / 1500W



3.15

42" Plasma
42吋液晶電視 (含插座)



3.16

19" Plasma
19吋液晶螢幕 (含插座)



Projector
投影機



(如有需求·請洽專案窗口)

(Should you have any need, please contact us)

hi-fi equipment
音響設備



(如有需求·請洽專案窗口)

(Should you have any need, please contact us)

3.17

Water Dispenser with Water*3
飲水機 (含插座、3 桶水)



Coffee machine 咖啡機
(以實際提供為準·圖片僅為示意)



(如有需求·請洽專案窗口)

(Should you have any need, please contact us)

3.18

Refrigerator
小冰箱
W48D54H86CM (含插座)



Refrigerated Display
三、四、五呎 蛋糕櫃



(如有需求·請洽專案窗口)

(Should you have any need, please contact us)

Art word (PVC、Foam、3D)
美工字 (PVC、珍珠板、寶麗龍)

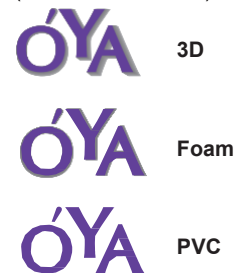

(如有需求·請洽專案窗口)

(Should you have any need, please contact us)

O'YA DESIGN It's your best choice



	OLILY	OLIVON	ODC	O'YA	OJK
Service items	Assist Taiwanese Company to Attend International Exhibition • International Exhibition Construction Management • International Event Planning & Executive • National Pavilions Design	Assist Chinese Company to Attend International Exhibition • International Exhibition Construction Management • International Event Planning & Executive • National Pavilions Design	Brand Identity Design • Corporate Identity Design • Website Identity Design • Video Visual Design	Event Activity Planning & Executive • Idea Marketing Planning • Art Exhibition Promotion • Commercial Retail Sales & Show Room Design	Professional Exhibits Construction Dismantling • Warehouse Management • OCTANORM system material • Exhibition Appointed Contractor

OLILY design group and the global exhibition team combined the multicultural activities and the professional team to create the new and innovative and diversified kinds of exhibition and events with efficiency service network of resources.

Service Contact : +886-2-2655-2777 / Mail: daven@o-ya-design.com



著作權歸屬歐也空間室內裝修設計(股)公司·任何未經授權之轉述、引用、重製等之侵權行為·本公司將依法追究賠償責任·台北市 115 南港區三重路 19-6 號 10 樓(南港軟體園區)C 棟 Tel : +886-2-2655-2777 Fax : +886-2-2655-2999 Website : www.olily.com/cblog



www.taitronics.tw



www.aiottaiwan.com